

hohner

UNIVERSAL 43/6 S

Narrow Stitching Head

Edition 04/2010

CE

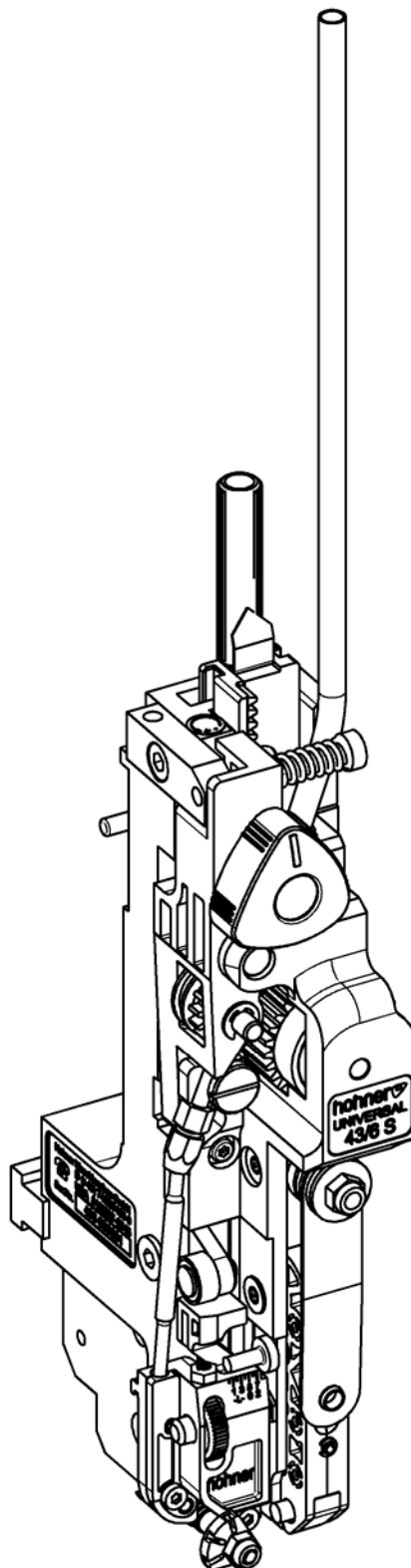

Customer Entries

Stitching head no:

Machine manufacturer:

Type of manufacturer:

Manufacturer' s Address

Company name: Hohner Maschinenbau GmbH

Street: Gänsäcker 19

Town: D-78532 Tuttlingen

Telephone: +49 (0) 7462 / 9468-0

Fax: +49 (0) 7462 / 9468-20

Email: info@hohner-postpress.com

Internet: <http://www.hohner-postpress.com>

Operating-Instructions

Document: Translation of the German
original Operating-Instructions

Version: 04/2010

Spare Parts / Customer Service

Service telephone no: +49 (0) 7462 / 9468-23

List of Contents

1 SAFETY INFORMATION	6
1.1 Purpose of this document	6
1.2 The operator	6
1.3 Safety symbols and the displays that have been used	6
1.4 Obligation and liability	7
1.5 Correct use	7
1.6 Organisational measures	7
1.7 Safety and protective devices	7
1.8 Non-formal safety measures	7
1.9 Staff training	7
1.10 Parts of the equipment which are particularly dangerous	8
1.11 Maintenance and repair work, elimination of faults	8
1.12 Structural modifications to the stitching head	8
1.13 Cleaning the machine and the disposal of waste products	8
2 DESCRIPTION OF THE STITCHING HEAD	10
2.1 General overview	11
2.2 Conformity	11
2.3 Marking and type plate	11
2.4 Technical data	11
2.4.1 Normal stitch	12
2.4.2 Loop stitch	13
2.5 Dimensional sheet	15
2.6 Outfitting of the stitching head	15
2.6.1 Basic features	15
3 OPERATION	16
3.1 Installation of the stitching head	17
3.1.1 Clamping the stitching head	17
3.1.1.1 Lateral adjustment of the stitching head	17
3.1.1.2 Front adjustment of the stitching head	17
3.1.2 Fitting the wire guide	19
3.1.3 Fitting the clincher box	21
3.1.4 Adjusting the clincher box	23
3.2 Feeding the stitching wire	25
3.3 Removing the stitching wire	25
3.4 Removing the wire guide tubes in the event of a wire jam	25
3.5 Straighten the stitching wire	27
3.6 Setting the stitch length	29
3.6.1 Basic setting of the stitch length	29
3.6.2 Fine adjustment of the stitch length	29
3.6.3 Setting the leg length of the stitch	31
3.7 Setting the former	33
3.8 Spine centering parts	35
3.8.1 Fitting the holding down device - “old” model	35
3.8.2 Fitting the slide	35
3.8.3 Setting the holding down device	35
3.8.4 Fitting the holding down device - “new” model	37
3.8.5 Fitting the slide	37
3.8.6 Setting the centering prism	37
3.9 Exchangeable parts – Changeover (stitch type)	38
3.9.1 Exchangeable parts	39
3.9.2 Procedure	39
3.9.3 Adapting the stitch and leg length settings	39
3.10 Basic setting of Stop-Stitch (ST 100)	41

4	SERVICING	42
4.1	Lubrication	43
4.1.1	Lubricants	43
4.1.2	Lubrication plan	43
4.2	Installation and replacement of parts	44
4.2.1	Replacing the former	45
4.2.2	Removing the bender stop	47
4.2.3	Replacing the bender	49
4.2.3.1	Bender lock	49
4.2.3.2	Removing the bender lock	49
4.2.4	Replacing the knife	51
4.2.4.1	Rotating/Changing the flat knife	51
4.2.4.2	Replacing the circular knife	51
4.2.4.3	Adjusting the circular knife	51
4.2.5	Replacing the driver (normal stitch)	53
4.2.6	Replacing the driver (loop stitch)	53
4.2.7	Replacing the clincher	55
5	FAULTS	56
5.1	Causes and elimination of faults	56
7	LIST OF SPARE PARTS	E1

1 Safety Information

1.1 Purpose of this document

This document will inform the operator of the **Stitching Head M 43/6 S** of the following:

- The safety symbols and signs
- The packing of the machine and its transportation
- The function and operation of the machine
- Commissioning the machine
- The elimination of faults which arise
- Servicing

Familiarity with this Operating Manual is thus a prerequisite for the safe and correct operation of the stitching head. It must be read carefully by the operator before the machine is commissioned. Keep the manual safely in a place where it is readily available and which is close to hand for persons working on the machine.

1.2 The operator

The **Stitching Head M 43/6 S** must only be operated by trained personnel.

Training will be undertaken by the manufacturer or by persons who have been authorised by the manufacturer to undertake such training.

1.3 Safety symbols and the displays that have been used



This symbol indicates immediate danger to the life or health of persons in the immediate vicinity of the machine.

Non-observance of dangers which are so indicated can have grave consequences and can cause serious damage to health, or may even to lead to deaths.



This symbol indicates that a potentially dangerous situation has arisen.

Non-observance of dangers which are so indicated can lead to slight injuries to persons or damage to equipment.



TIP

This symbol indicates that tips on how to use the machine or particularly useful information are available.

These will help you to use all of the functions of the machine in an optimal manner.

- ***This symbol requires you to take action.***
- ***This sign serves as a symbol for listing items.***

1.4 Obligation and liability

The **43/6 S Stitching Head** has been built according to state-of-the art technology under observance of all the recognised safety regulations. However, dangers to life and limb of the user or third parties and damage to the system or other material assets can still occur during use. The stitching head should only be used,

- for the purpose for which it was designed
- when it is in a perfect technical condition.

Faults which could reduce levels of safety when using the machine must be eliminated immediately.

Warranties and liability on the part of the manufacturer are fundamentally covered by the regulations laid down in our "General sales and delivery conditions".

Warranty claims will only be valid if the number label is affixed (number label on stitching head housing).

1.5 Correct use

The **Stitching Head 43/6 S** is designed exclusively for binding brochures and leaflets or similar items.

Any use of the machine contrary to that described above is forbidden, since incorrect use of the machine can present a danger.

1.6 Organisational measures

The user of machine is required to provide the required personal safety equipment. All existing safety devices should be checked regularly.

1.7 Safety and protective devices

All safety and protective devices must be correctly attached to the machine and should be in full working order before every start-up of the machine and **Stitching Head 43/6 S**. Safety and protective devices may only be removed:

- After the machine has come to a standstill **and**
- As security against the machine starting up again.

1.8 Non-formal safety measures

The Operating Manual must be kept so that it is permanently at hand at the machine with **Stitching Head 43/6 S**. There are also generally valid local regulations concerning accident prevention and environmental protection measures which should be made available and observed in addition to those described in the Operating Instructions.

All safety and danger signs on the machine should be maintained in a legible condition and should be renewed where necessary.

1.9 Staff training

Only trained and instructed personnel may install, operate, set and maintain the stitching head.

Safety Information

1.10 Parts of the equipment which are particularly dangerous

There is a **risk of injury** in the area of moving parts of the stitching head.



1.11 Maintenance and repair work, elimination of faults

Undertake the required setting, servicing and inspection work on schedule.

The machine may only be operated in cycle mode during all servicing, inspection and repair work on the **Stitching Head 43/6 S**.

Always make absolutely sure **that the machine is only being operated by one person in order to avoid any influence to the machine by any other persons.**



1.12 Structural modifications to the stitching head

Changes to the stitching head, additions or modifications may only be undertaken with the manufacturer's permission.

1.13 Cleaning the machine and the disposal of waste products

The functionality of the stitching head and perfect processing of the product can only be guaranteed over a prolonged period of time if the stitching head is regularly cleaned and maintained in accordance with the standard methods of mechanical engineering.

In this regard, particular attention should be paid to the regular removal of trimmed paper residue and paper dust, as these can result in jamming of the stitching head or increased wear.



Substances and materials used (e.g. solvents and lubricants) must be handled correctly and disposed of in an environmentally friendly manner.

Description of the Stitching Head

2 Description of the Stitching Head

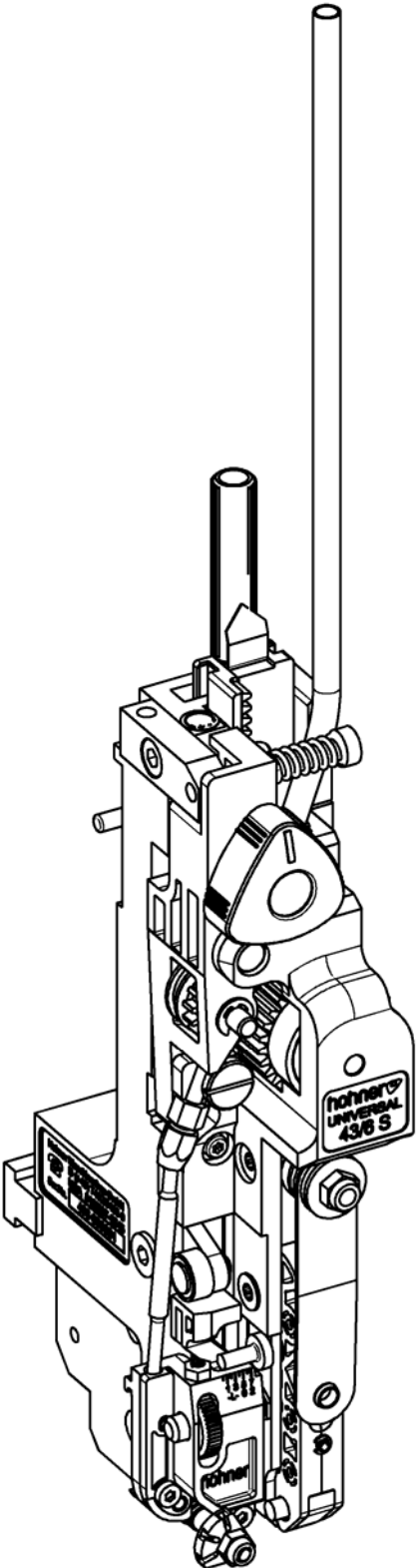

Fig. 1

2.1 General overview

- Fig. 1 -

2.2 Conformity

Please observe the document attached:



"EC Declaration of Incorporation according to the EC Machinery Directive 2006 / 42 / EC"

2.3 Marking and type plate

The type plate is located at the front of the stitching head.

The serial number of the stitching head is indicated on an adhesive label at the right-hand side of the housing.

2.4 Technical data

Net weight of the stitching head	1,4 kg / 3.1 lbs
Quality of the stitching wire	Only use perfect quality classes, in normal or steel strength as required. Pay attention to abrasion resistance, as heavy abrasion will clog the wire-guidance parts.



Description of the Stitching Head

2.4.1 Normal stitch

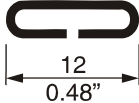
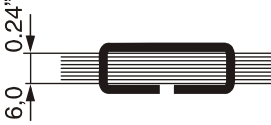
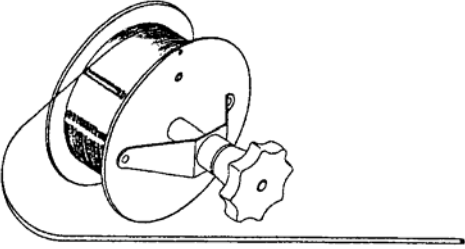
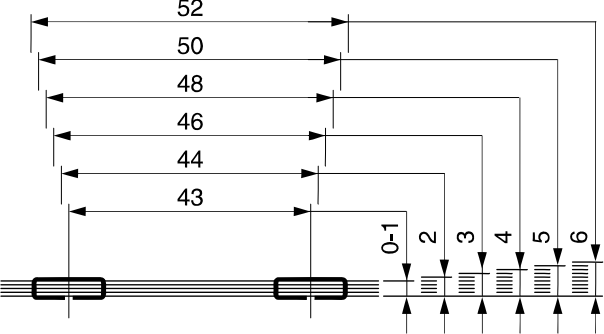
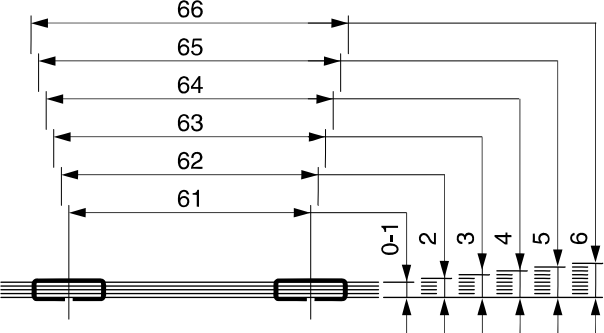
Wire stitch dimensions	
Max. stitch thickness	
Stitching wire coil No. 24 - 26 Ø 0.60 - 0.50 mm (Ø 0.024 - 0.020 in.) or: Stitching wire coil No. 26 - 28 Ø 0.50 - 0.40 mm (Ø 0.020 - 0.016 in.)	
Possible distances between wire stitches and stitch thicknesses in mm	
With holding down device	

2.4.2 Loop stitch

	Standard - L6 -	- L8 -
Wire stitch dimensions		
Max. stitch thickness		
Stitching wire coil: No. 24 - 26 Ø 0.60 - 0.50 mm Ø 0.024 - 0.020 in.		
Possible distances between wire stitches and stitch thicknesses in mm		
With holding down device		

Description of the Stitching Head

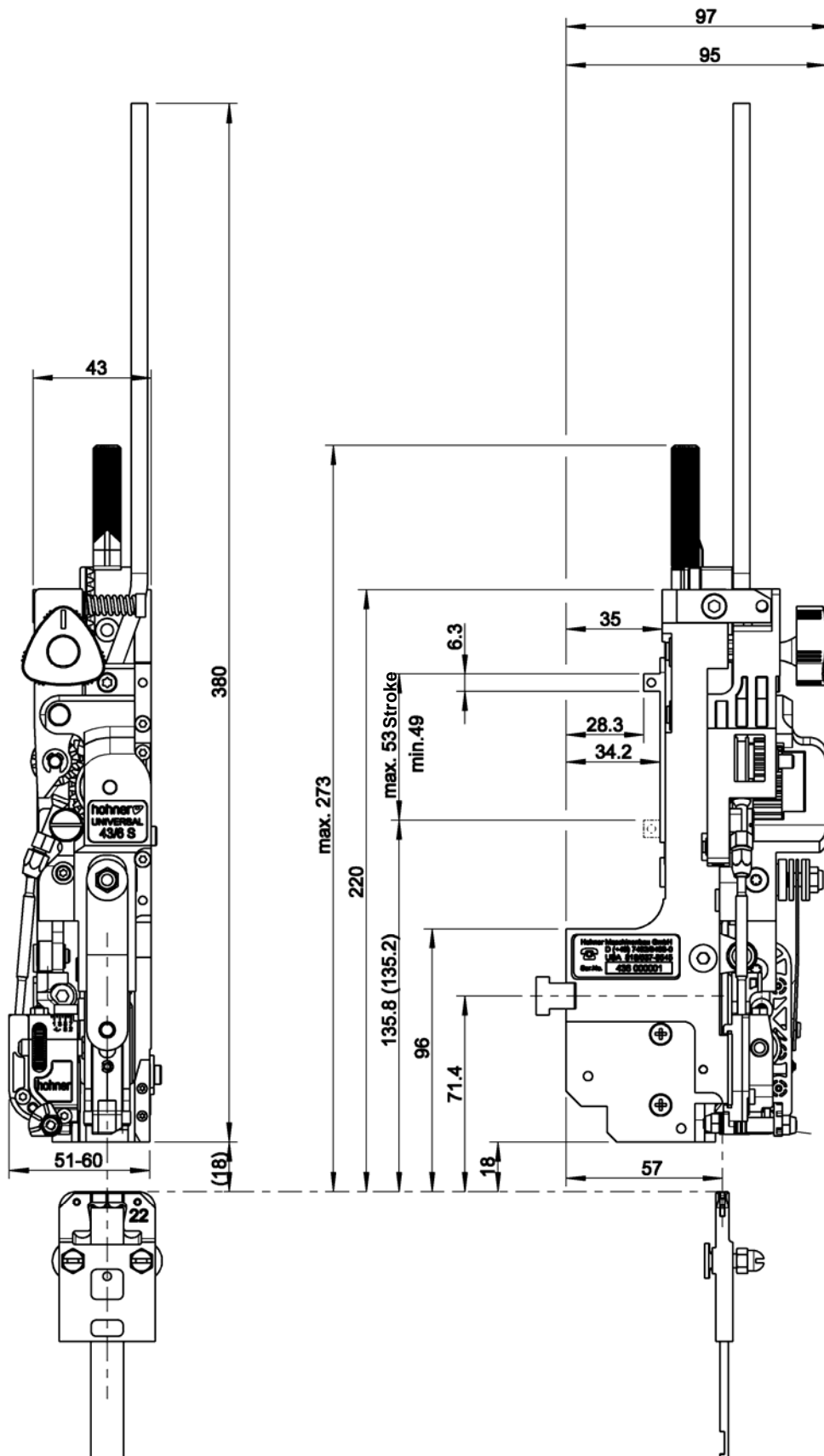

Fig. 2

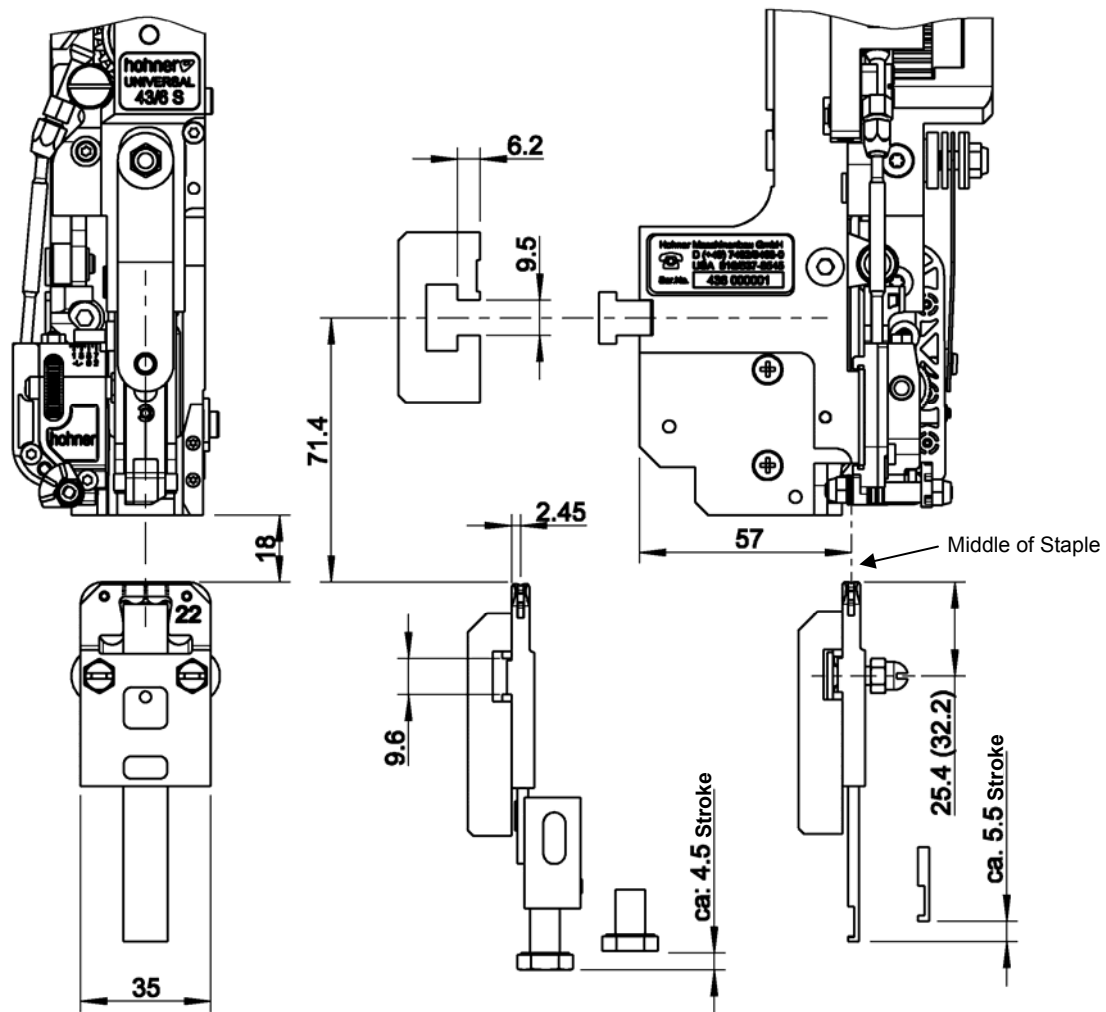

Fig. 3

2.5 Dimensional sheet

- Fig. 2 , Fig. 3-

2.6 Outfitting of the stitching head

2.6.1 Basic features

The stitching head is delivered with the following accessories:

DESIGNATION	ORDER NUMBER
Clincher box setting gauge	31 64 448
Torx screwdriver T10	46 00 044
Torx screwdriver T20	46 00 045
Allen key with T-handle SW4 x 70 / SW4-150	46 64 098 / 46 00 033
Adjusting handle	94 64 115
Wire guide, complete	according to machine manufacturer
Clincher box, complete	according to machine manufacturer

Operation

3 Operation

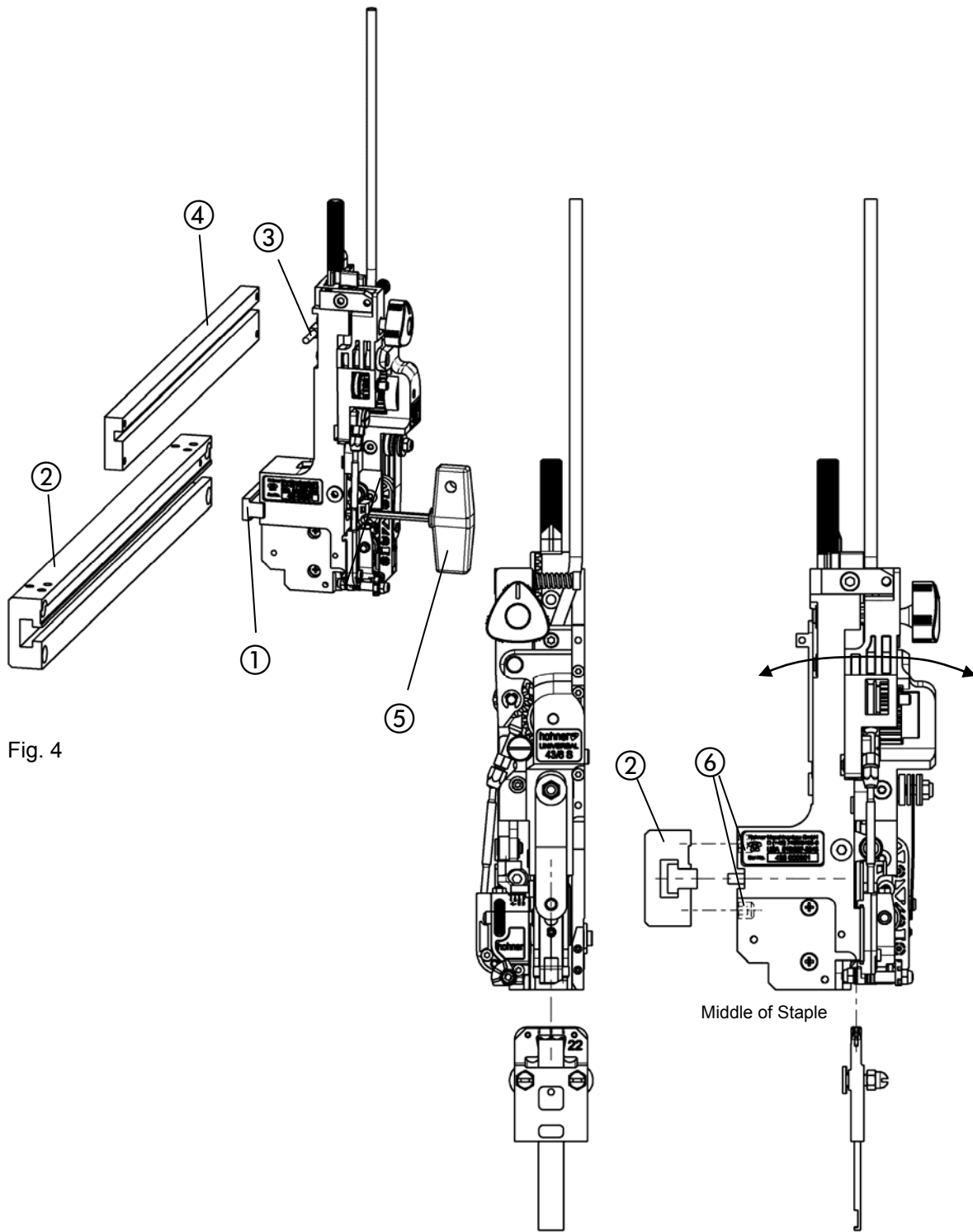

Fig. 4

Fig. 5

3.1 Installation of the stitching head

3.1.1 Clamping the stitching head

- Fig. 4 -

The stitching head is held by a tenon block which is inserted into the stitching head mounting on the machine.

- Unscrew tenon block from the stitching head with Allen key SW4 ⑤.
- Introduce tenon block laterally into the stitching head mounting ②.
- Insert stitching head into stitching head mounting, so that the driver lug ③ can be inserted into the stroke bar ④ and the tenon block fits into the stitching head.
- Fix the stitching head by tightening the tenon block in the stitching head mounting using the Allen key ⑤.

3.1.1.1 Lateral adjustment of the stitching head

- Fig. 4, Fig. 5 -



The center of the wire formed parts within the stitching head must be set to the desired stitching position for the wire stitch by lateral adjustment.

- Loosen the tenon block ① with the Allen key ⑤.
- Move the stitching head sideways, until the desired position is reached.
- Fix the tenon block in the stitching head mounting ② with the Allen key.

3.1.1.2 Front adjustment of the stitching head

- Fig. 5 -



The lifting movement of the wire formed parts must drive the stitch accurately into the clincher box forming gap. (Cf. Chap. 3.1.4). If the center of the wire stitch is located too far in front of or behind the clincher box, or if the lifting movement is not precisely aligned with the clincher box, this can be corrected by adjusting the set screws ⑥ on the stitching head.

- Remove stitching head.
- Adjust set screws ⑥.
- Fit stitching head.

Operation

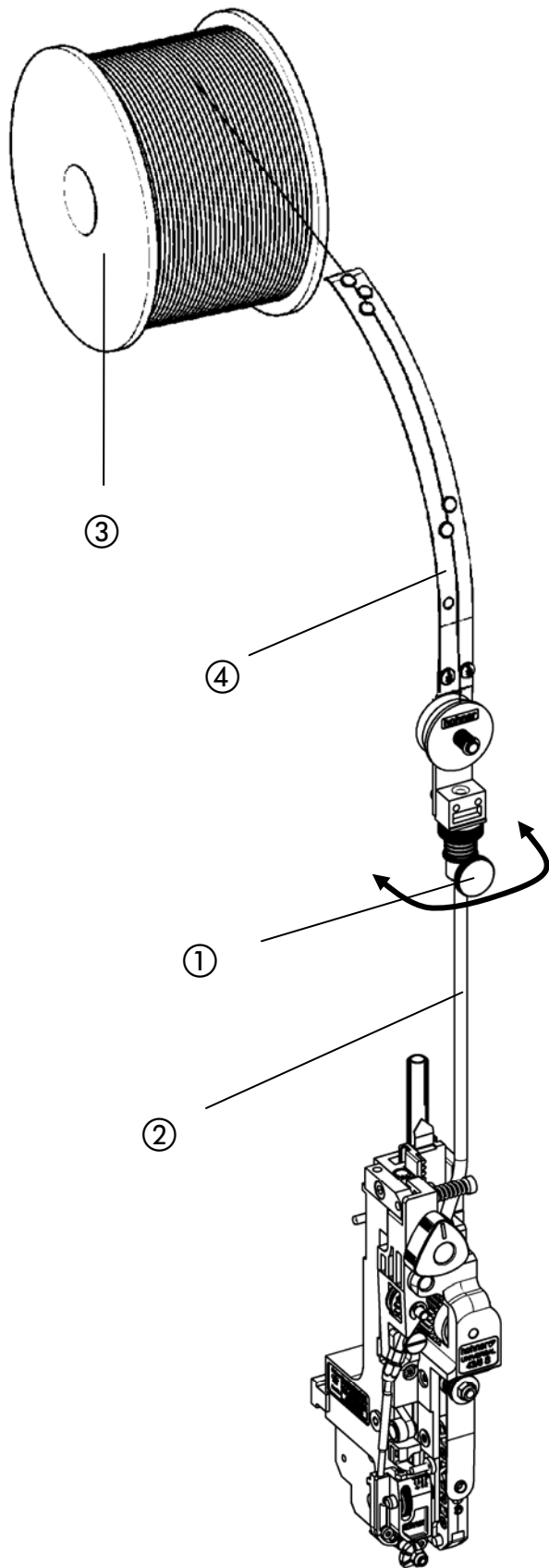

Fig. 6

3.1.2 Fitting the wire guide

- Fig. 6 -

- Loosen the knurled screw ① and place the wire guide ④ on the wire guide tube ②.
- Align wire guide ④ to wire roller ③ , in order to ensure perfect wire guidance.
- Tighten knurled screw ① in order to fix the wire guide ④.

Operation

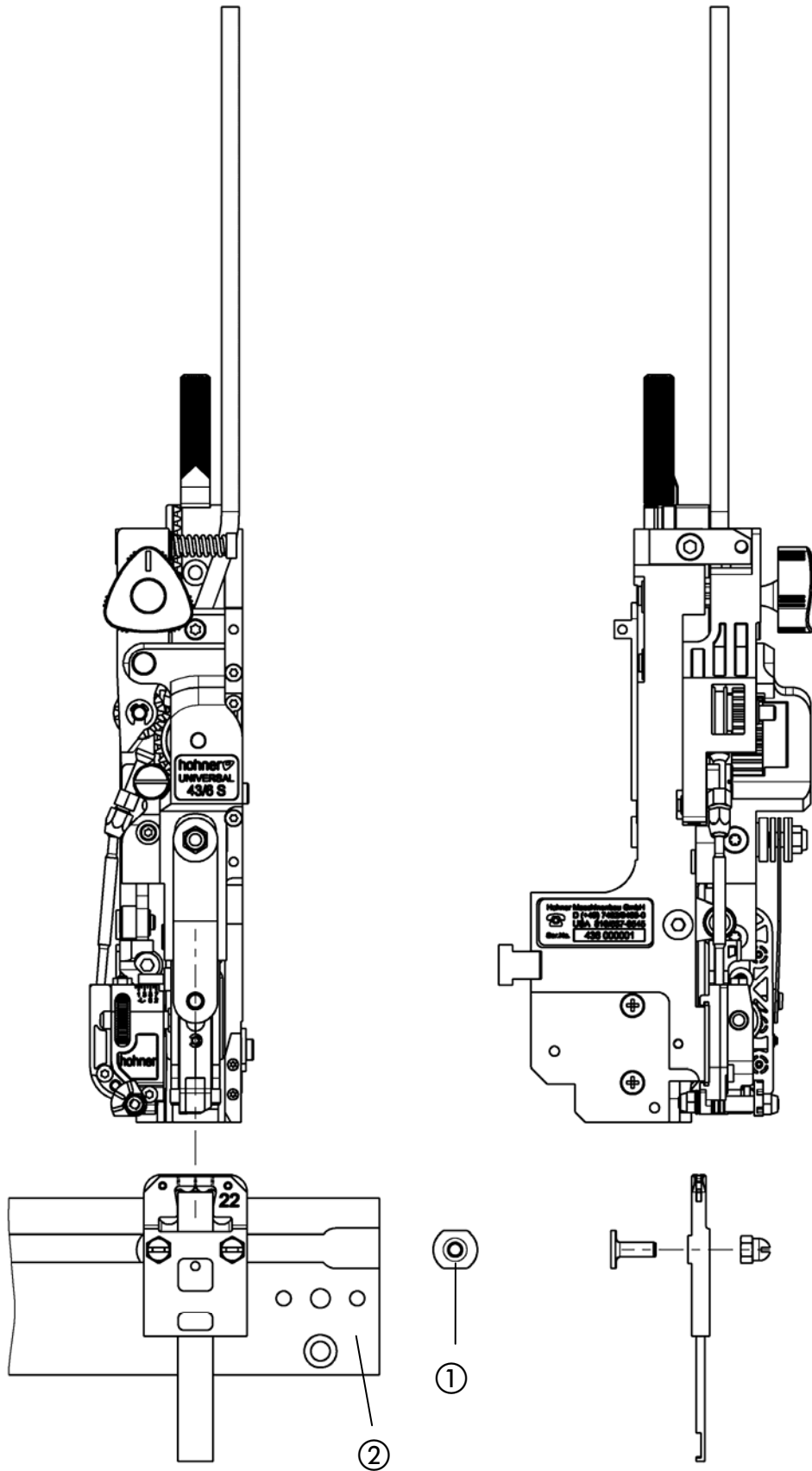

Fig. 7

3.1.3 Fitting the clincher box

- Fig. 7 -

- Install slotted screws ① (and tenon block) laterally into the clincher box mounting rail ②.
- Slide clincher box beneath the center of the stitching head.
- Fix clincher box by tightening the locking nuts (and locking screws).

Operation

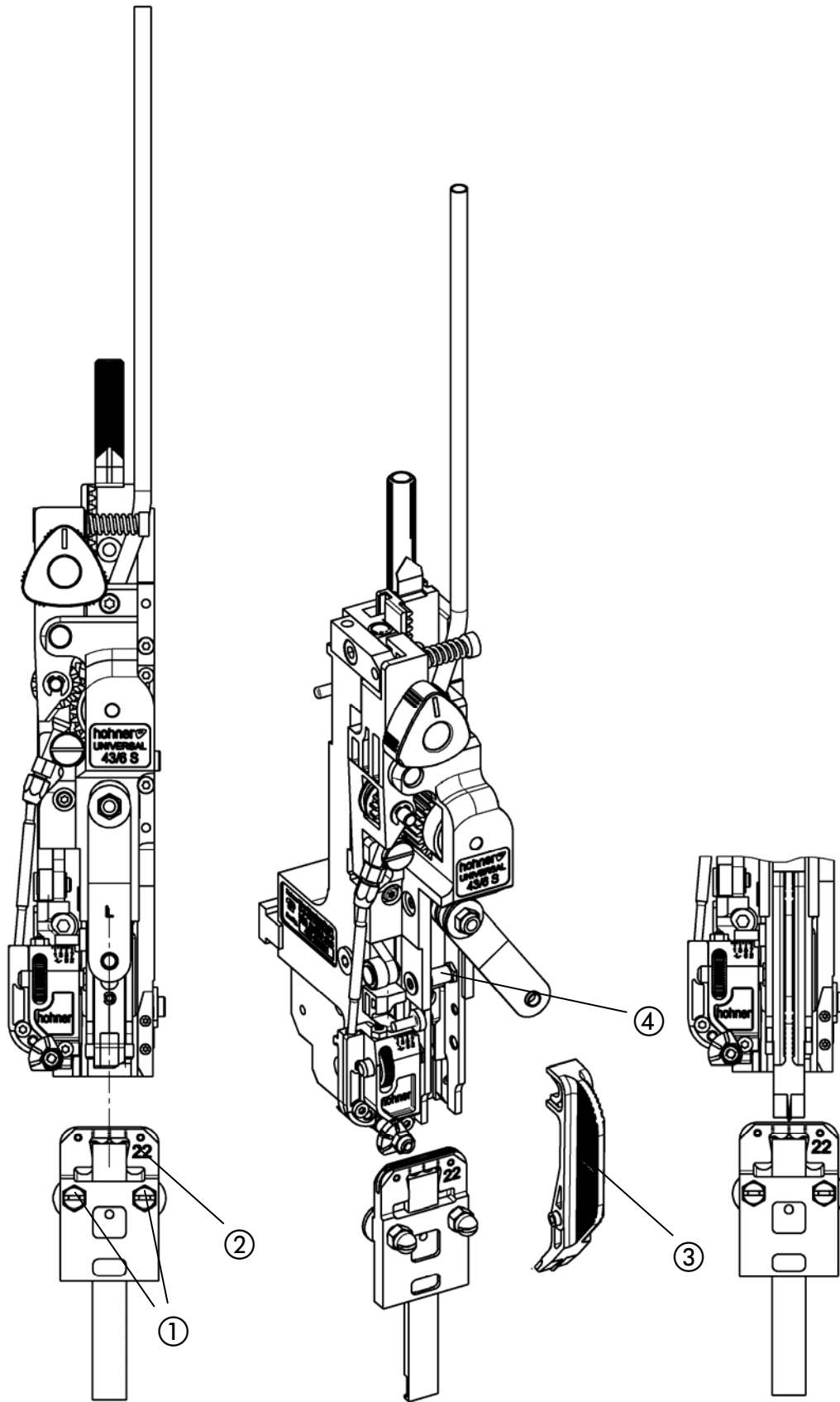

Fig. 8a

Fig. 8b

Fig. 8c

3.1.4 Adjusting the clincher box

- Fig. 8a -

The center of the bender inside the stitching head must be precisely aligned to the center of the clincher box.

- Loosen locking nuts (or clamping screws) ① (and locking screws).
- Move clincher ② box until it is precisely aligned with the center of the bender.
- Fix clincher box by tightening the locking nuts (or clamping screws) (and locking screws).

Using the clincher box setting gauge

- Fig. 8b, Fig. 8c -

- Remove former (see 4.2.1). Place gauge ③ on former locating pin ④ and turn downward against stopper. The clincher box can be precisely aligned by aligning the gauge with the scale graduation marks.
- Tighten clamping nut ① and remove gauge ③. Fit in former.

Operation

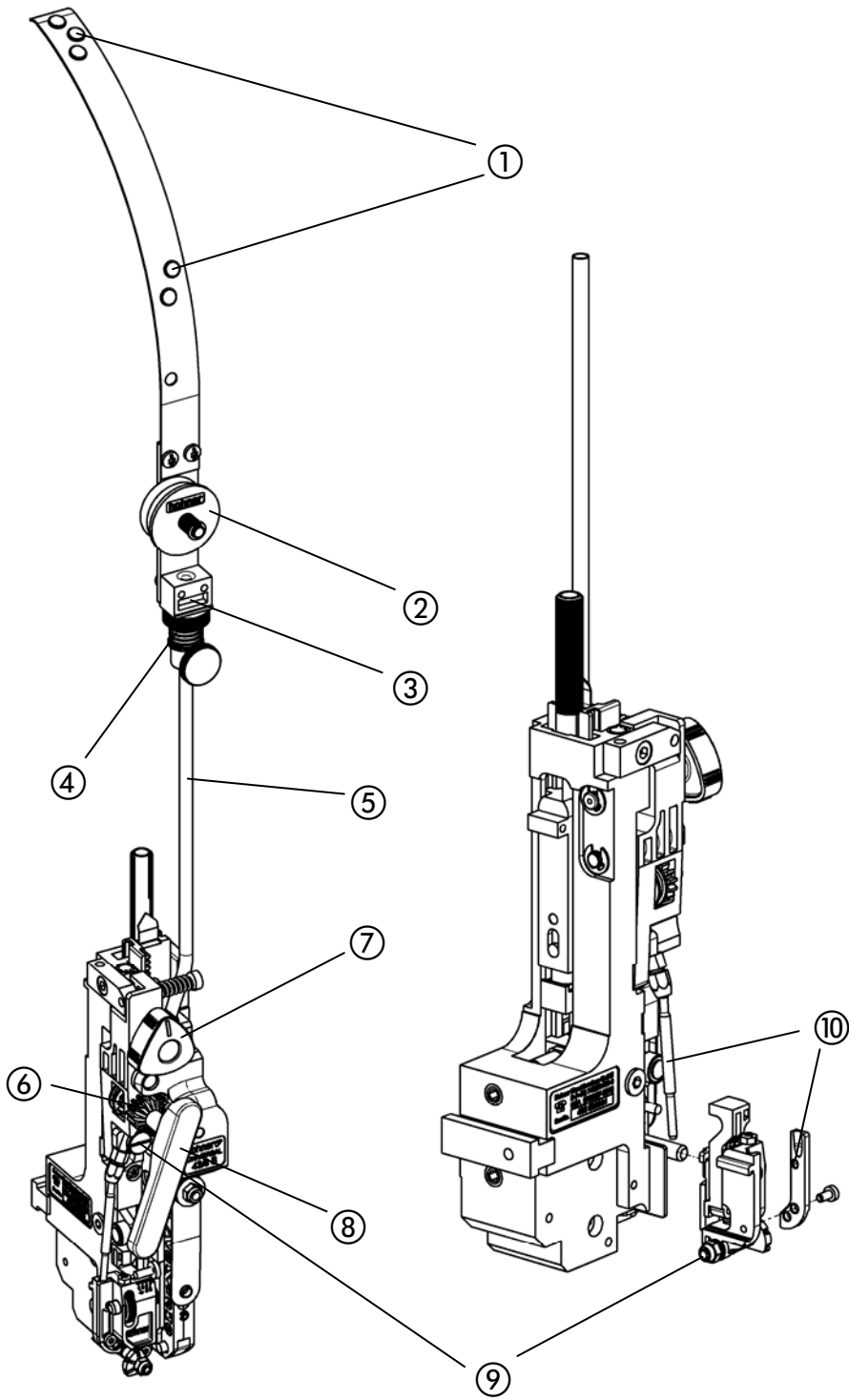

Fig. 9

Fig. 10

3.2 Feeding the stitching wire

- Fig. 9 -

- Shut off the wire transport (move triangular handle ⑦ until you see the feed wheels disengaged, marking line points to the right).
- Push the stitching wire through from above, as follows:
through the eyes ① of the wire guide - between the two felt disks ② through into the wire return lock ③ - through the wire guidance tube ⑤ and between the two feed wheels ⑥.
- Restart the wire transport (turn triangular handle ⑦ to the left, marking line points upwards or downwards).
- Mount adjusting handle ⑧.
- Convey the wire to the knife by turning the adjusting handle ⑧ to the right.

3.3 Removing the stitching wire

- Shut off the wire transport (move triangular handle ⑦ until you see the feed wheels disengaged, marking line points to the right).
- Press adjusting disk ④ on wire return lock downwards, in order to eliminate its clamping effect, and pull the wire out.

3.4 Removing the wire guide tubes in the event of a wire jam

- Fig. 10 -

If a wire jam has occurred in the area of the wire guide tubes, this can be eliminated more easily by removing the wire guide tubes.

- Shut off the wire transport (move triangular handle ⑦ until you see the feed wheels disengaged, marking line points upwards or downwards).
- Loosen the clamping screw ⑨ (slotted or Torx screw) and remove wire guide tubes ⑩
- Disentangle wire and remove from wire guide tubes.
- Press adjusting disk ④ on wire return lock downwards in order to eliminate its clamping effect and pull wire out.

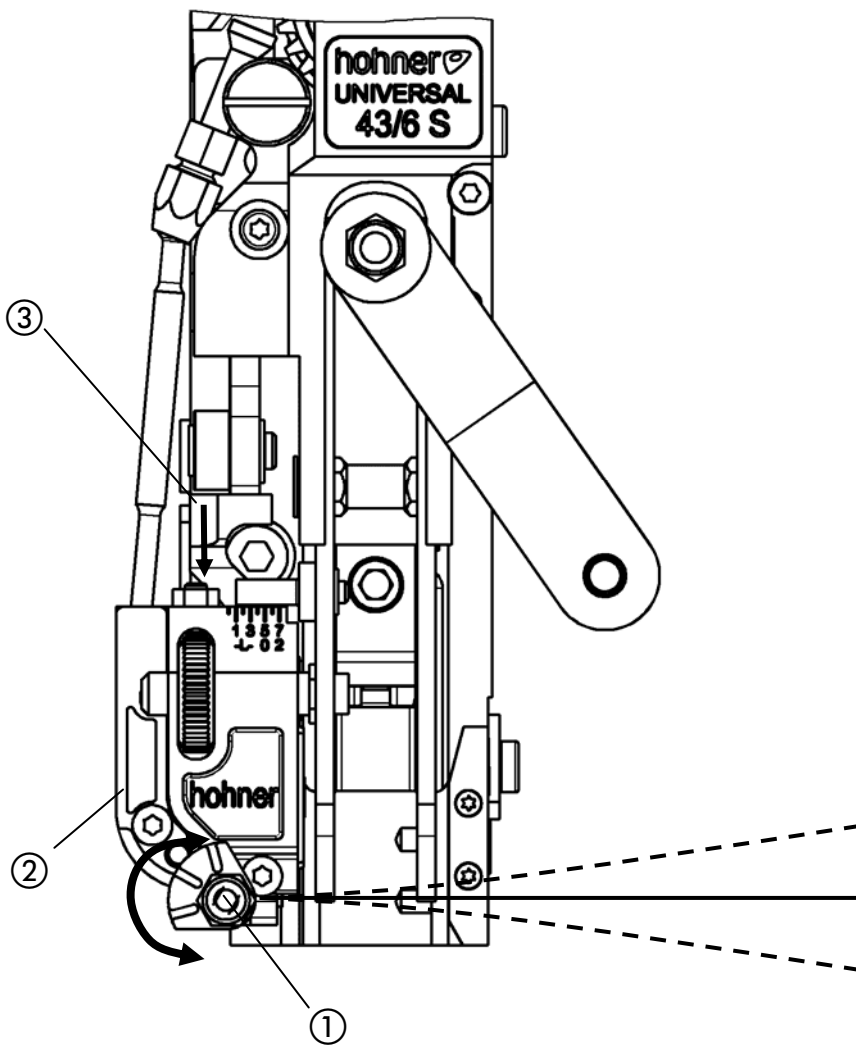

Fig. 11

3.5 Straighten the stitching wire

- Fig. 11 -

The stitching wire must run absolutely straight out of the circular knife. The wire feed can be set to run absolutely straight by turning the wire alignment roller ① which is arranged on eccentric bearings.

Wire straightening procedure:

- First remove former. (cf. 4.2.1)

a) Activate the machine's jog switch if possible.

b) Manual wire feed (cf. 3.2 Feeding the stitching wire)

Wire can be fed by turning the provided adjusting handle in the clockwise direction. When doing this, it is a good idea to cut off any overlong pieces of wire, by pressing down the knife slider ③.

- Turn eccentric fixing of the wire alignment roller ① with the screwdriver until the stitching wire runs absolutely straight out of the circular knife.

Operation

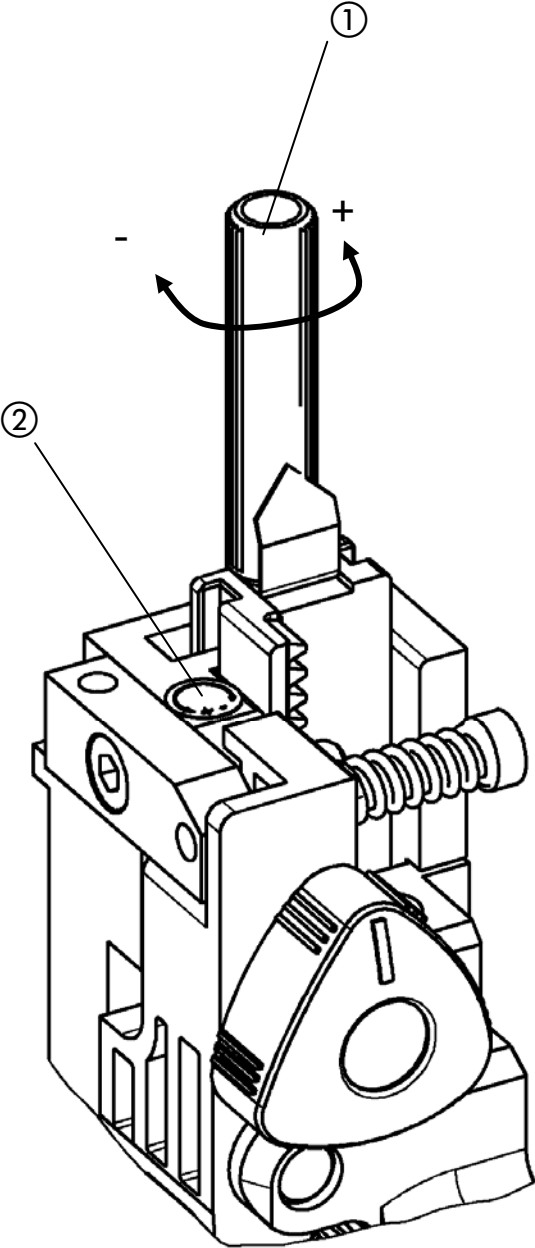

Fig. 12

3.6 Setting the stitch length

3.6.1 Basic setting of the stitch length

The setting is dependent on the stroke length of your machine.
Basic setting is done ex works (referred to a stroke of 50 mm).

Normal stitching:

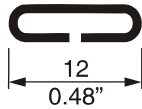

The recommended wire length for 2-sheet stitching is approx. 23 mm, the stitching unit must then be set to 2-sheet stitching.

Loop stitching standard stitch -L6-:

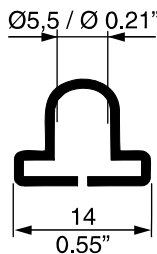

The recommended wire length for 2-sheet loop stitching is approx. 33 mm, the stitching unit must then be set to 2-sheet stitching.

Loop stitching special stitch - L8 -:



The recommended wire length for 2-sheet loop stitching is approx. 35 mm, the stitching unit must then be set to 2-sheet stitching.



When changing from normal stitching to loop stitching (standard -L6-) or vice-versa the stitch length required must be adapted.

Turn the knob ① by approx. 12.5 turns anticlockwise (+) for feeding more wire or clockwise (-) for feeding less wire.

3.6.2 Fine adjustment of the stitch length

- Fig. 12 -

Fine adjustment of the wire length is performed by means of test stitches. If the stitch is not the required length, more wire can be fed by **turning** knob ① **anticlockwise (+)**, or less wire can be fed by **turning** the knob **clockwise (-)** (cf. scale ②).

1 revolution of the knob feeds around 1,6 mm wire.

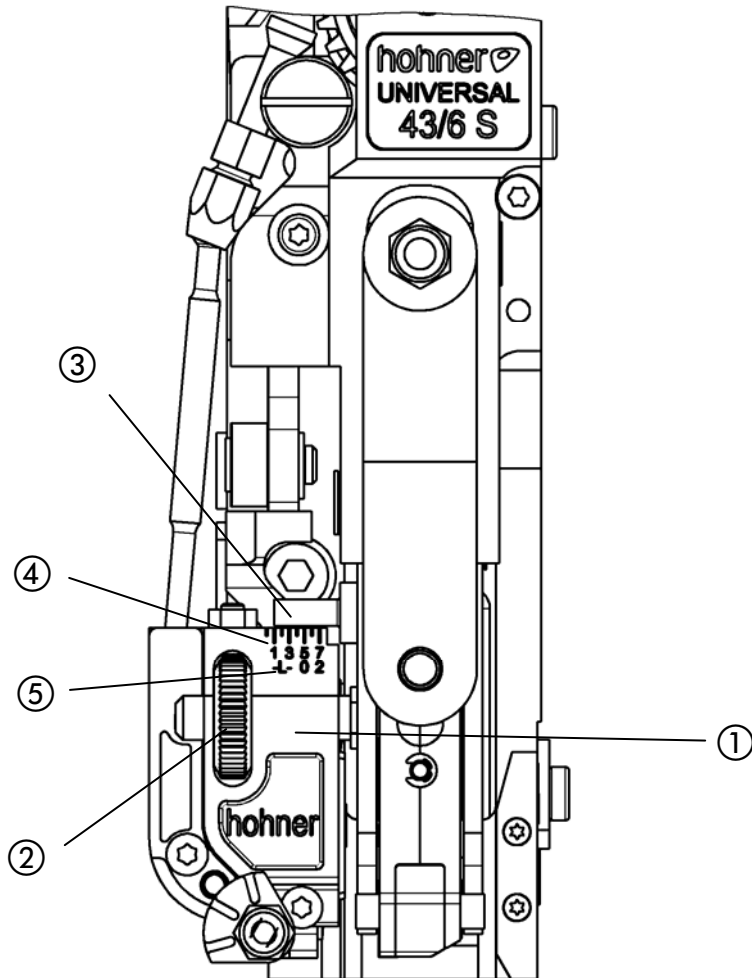

Fig. 13

3.6.3 Setting the leg length of the stitch

- Fig. 13 -

The leg length of the stitch is dependent on the thickness of the product to be stitched. The knife box ① can be adjusted in order to adapt to the thickness of the product. The end of the scale pin ③ marks the set value for the stitch thickness in mm. The upper values ④ on the scale (1 - 7) serve to set stitching thicknesses for **normal stitching** and the lower values ⑤ on the scale (-L-, 0 - 2) serve to set the thickness for **loop stitching**.

- Adjust knife box ① by turning the knurled wheel ②, until the end of the pin ③ indicates the value of the required stitch thickness (in mm) on the relevant scale.

- Test the leg length by a test stitch.

- Set the stitch to precisely the same leg length by turning the knurled wheel ②.

Normal stitch



set higher value



set lower value

Loop stitch



set higher value



set lower value

Operation

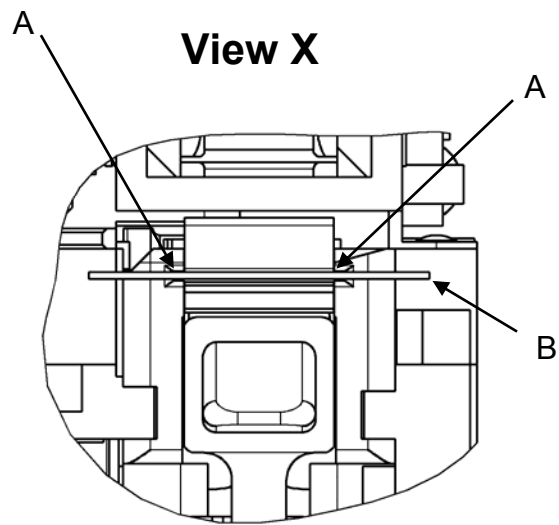
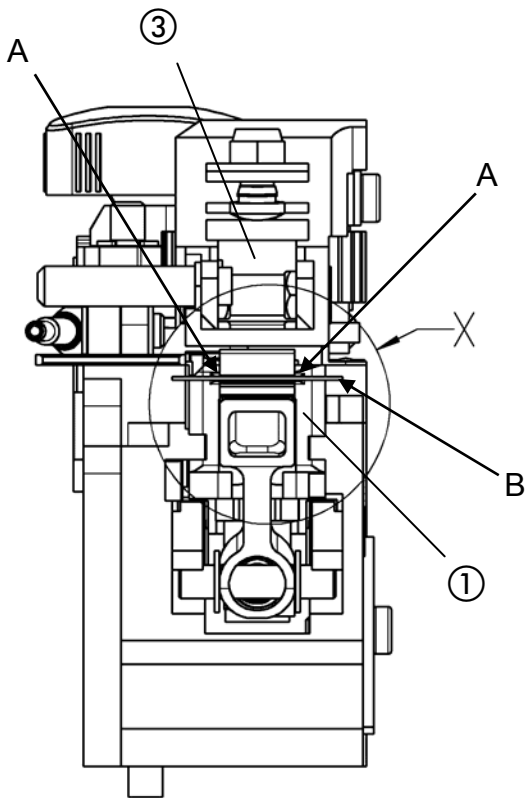

Fig. 14

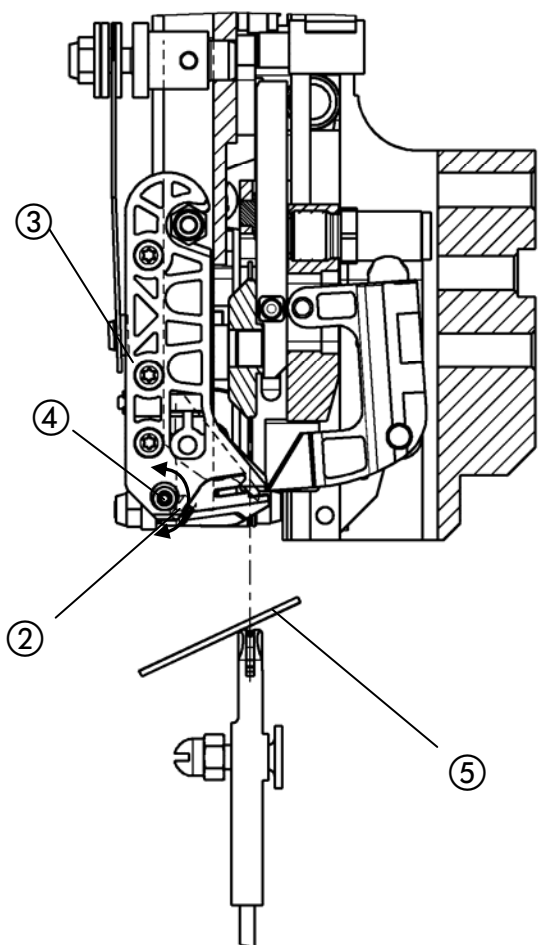

Fig. 15

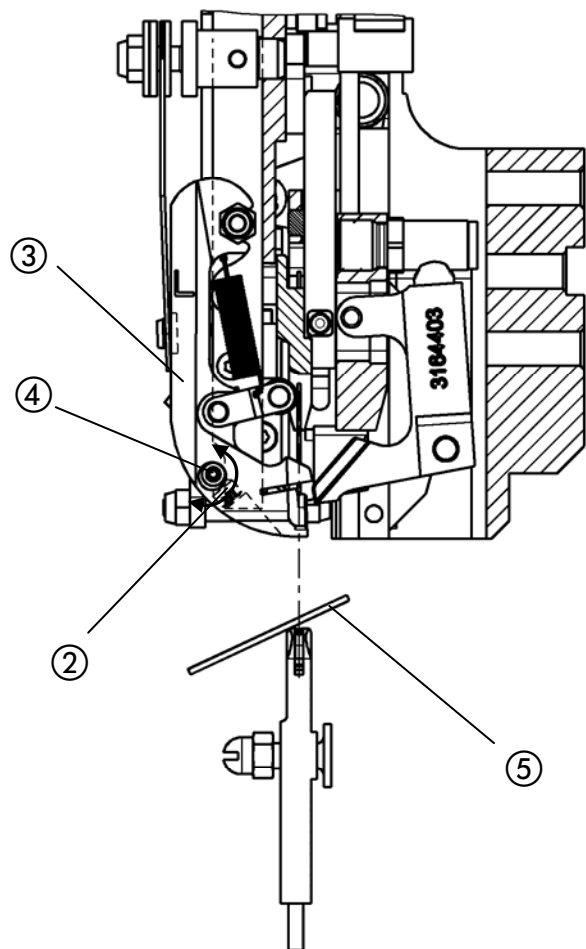

Fig. 16

3.7 Setting the former

- Fig. 14, Fig. 15, Fig. 16 -

To guarantee perfect stitching, the former ③ must swivel in far enough for the stitching wire (arrow B) to be positioned exactly beneath the center of the groove (arrow A) of the bender ①.

A mirror ⑤ placed on the clincher box can be used to check the setting on the fitted stitching head. The former ③ must keep the wire (arrow B) exactly aligned with the groove (arrow A) of the bender ①.

- Loosen the clamping screw ②.
- Turn the eccentric former stop ④ until precisely aligned.
- Tighten the clamping screw ②.



TIP

When changing the stitching wire thickness, the former setting should be checked and corrected if necessary.

Operation

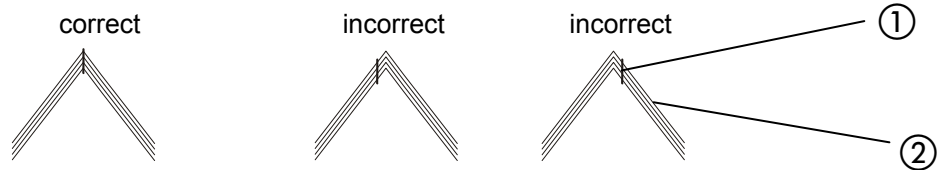

Fig. 17



Centering device – „old“ model

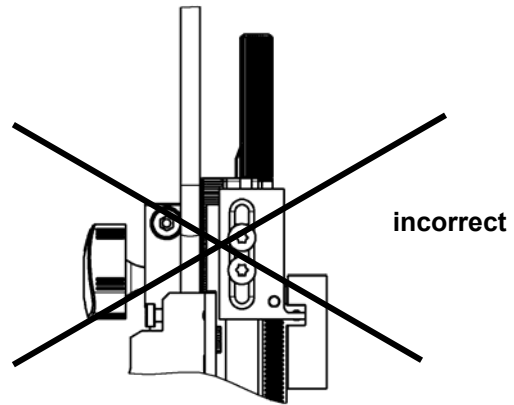

Fig. 18 a

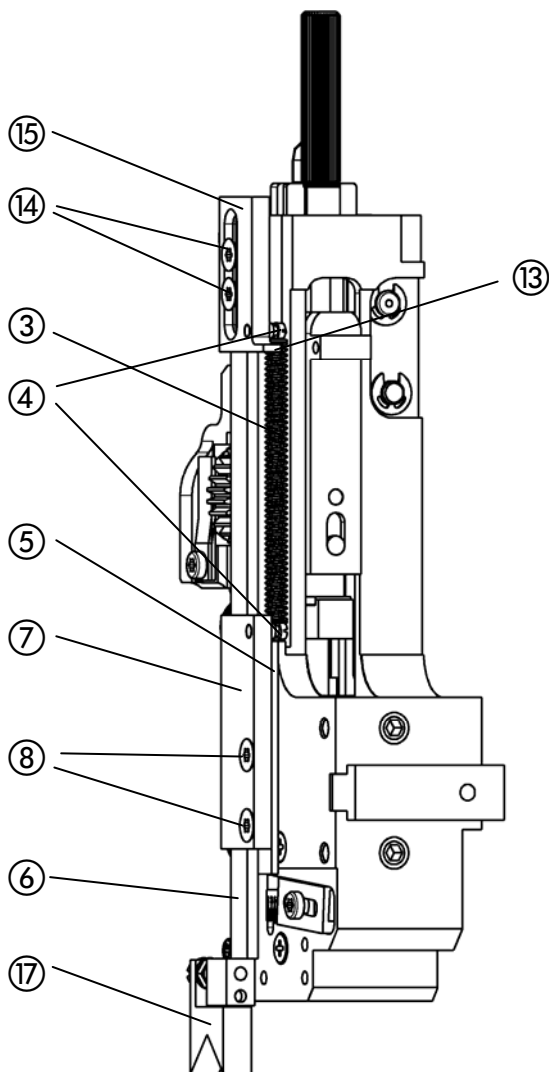

Fig. 18

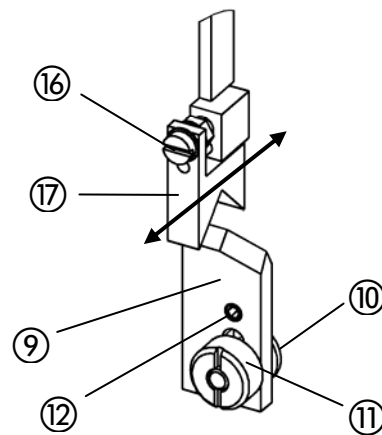
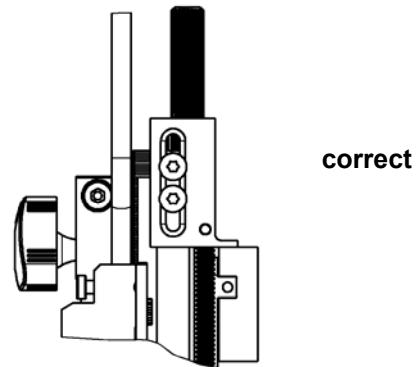

Fig. 18 b

3.8 Spine centering parts

The spine centering parts are only used for saddle stitching. They help to precisely position the stitch ① in the center of the sheet fold ② (cf. Fig. 17)

3.8.1 Fitting the holding down device - "old" model

- Fig. 18 -

- Attach tension spring ③ to the two spring bolts ④.

- Mount distance plate ⑤ on stitching head.



In the case of loop stitching an additional distance plate ⑤ is required as otherwise the longer wire would touch the centring V-block ⑰.

- Place complete rod assembly ⑥ with the guide plate ⑦ on the distance plate and fix to the housing with the help of the two countersunk screws ⑧ .

- Ensure that the rod assembly runs smoothly.

3.8.2 Fitting the slide

- Fig. 18b -

- Insert slotted screw ⑩ laterally into the clincher box mounting.

- Fix slide ⑨ with slot on slotted screw and tighten lightly using the locking nut ⑪.

- Push the complete slide ⑨ against the clincher box.

- Align the V-block of the slide to the center of the clincher box with the help of the M5 setscrew ⑫

- Set the height of the V-block to approx. 0.5 mm above the clincher box.

- Tighten the locking nut ⑪.

3.8.3 Setting the holding down device

- Fig. 18, Fig. 18a, Fig. 18b -

The centring V-block ⑰ on the lower part of the rod linkage should lie approx. 3 - 5 mm beneath the edge of the bender. This can be adjusted by moving the plate ⑮ in the slot.



- Install stitching head in the stitching unit (cf. 3.1). You must ensure that the **locating key ⑬ of the plate is positioned on the lifting bar and is not**, as is the case with the stitching head locating key, **inserted into the locating groove** (cf. Fig. 18a).

- Loosen the 2 countersunk screws ⑭.

- Drive rod linkage into plate ⑮ until the lower part of the rod linkage is positioned approx. 3 - 5 mm beneath the edge of the bender.

- Tighten the 2 countersunk screws ⑭.

The centring V-block ⑰ can be moved backwards or forwards by turning the adjusting screw ⑯.

- Move centring V-block ⑰ far enough backwards or forwards so that it is precisely aligned with the V-block of the slide ⑨ (see Fig. 18b)



Centering device – „new“ model

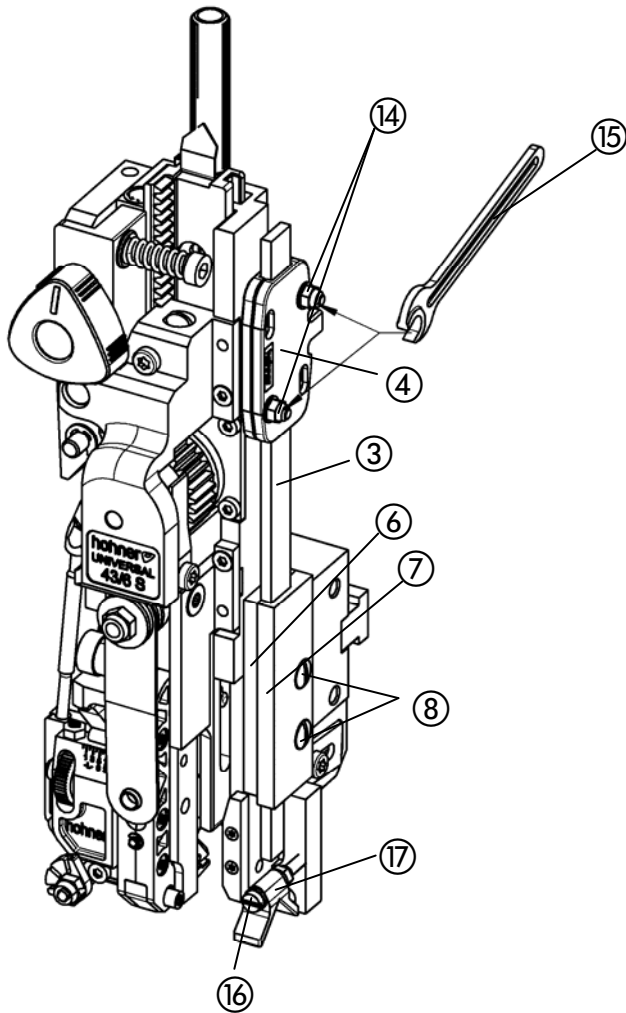

Fig. 19

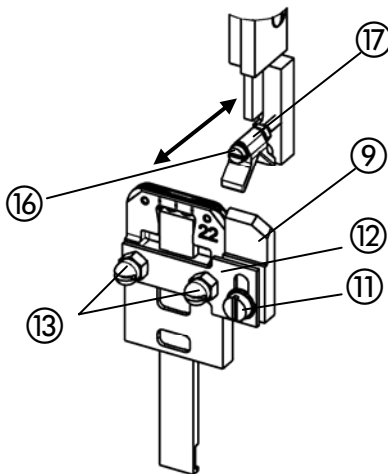

Fig. 19 a

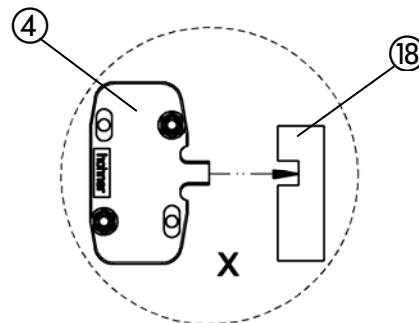
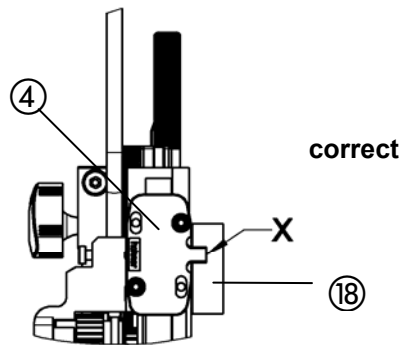
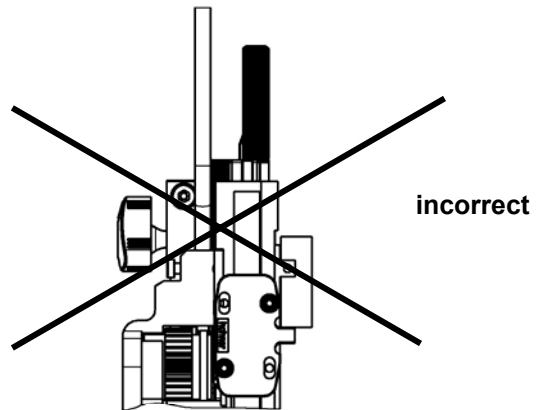
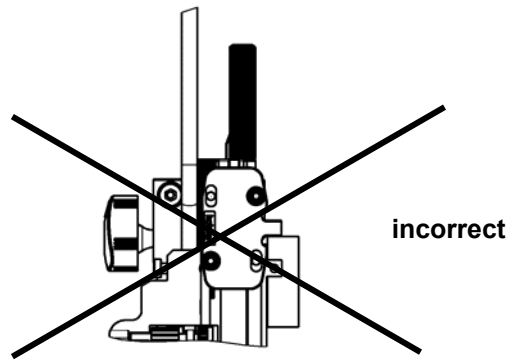

Fig. 19 b

3.8.4 Fitting the holding down device - “new” model

- Fig. 19 - (see Spare Parts List, page E 31)

- Put centering device rods ③ with carrier ④ between distance plate ⑥ and guide plate ⑦ (plates and rods should be slightly lubricated).
- Screw in screws ⑧ through the plate holes in the thread on the housing and tighten screw; the rods ③ should be parallel with the housing edge.

Proper setting of the carrier ④ is required to ensure correct functioning of the centering device. The two adjusting nuts ⑭ can be turned uniformly (same gap widths between both plates) with the open-end wrench ⑮.



TIP

The adjusting nuts ⑭ are tightened clockwise so that the centering device rods ③ can just be pushed upward and downward with two fingers (pushing force 15-20N).

Rods and guide plates should be slightly lubricated and the adjusting nuts be retightened ⑭ (if necessary) from time to time.



- A too strong setting causes higher wear of the functional components and markings on the stitching material.
- If the setting is too light the centering device might drop and block the stitching material.



When installing the stitching head with centering device (- Fig. 19b -) make sure that the carrier ④ is correctly placed in the groove of the drive beam ⑱ (view “X”).

3.8.5 Fitting the slide

- Fig. 19a -

- Attach slide ⑨ with holding plate ⑫ by means of nuts or screws ⑬ to the clincher box.
- Loosen clamping screw ⑩.
- Move slide ⑨ in the oblong hole and set the height of the slide prism ⑨ to approx. 0.5 mm above the clincher box.
- Tighten clamping screw ⑩.

3.8.6 Setting the centering prism

- Fig. 19a -

- The centering prism ⑰ can be shifted to the front or rear by turning the check screw ⑯.
- Shift the centering prism ⑰ until it is aligned with the slide prism ⑨.
 - Correct if necessary after having carried out test stitches.

Operation

3.9 Exchangeable parts – Changeover (stitch type)

Converting the stitching head (**standard stitch / loop stitch**)

Exchangeable parts for loop stitch

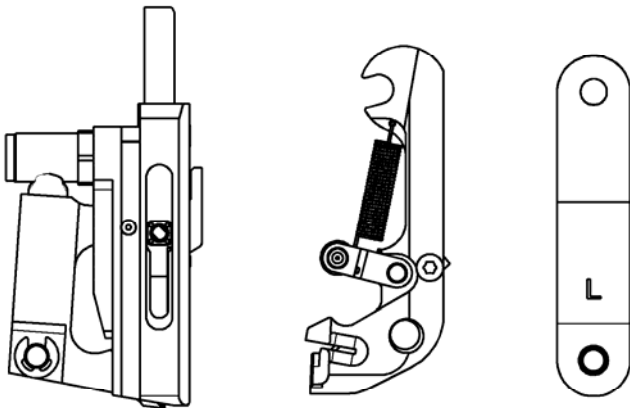

Fig. 20

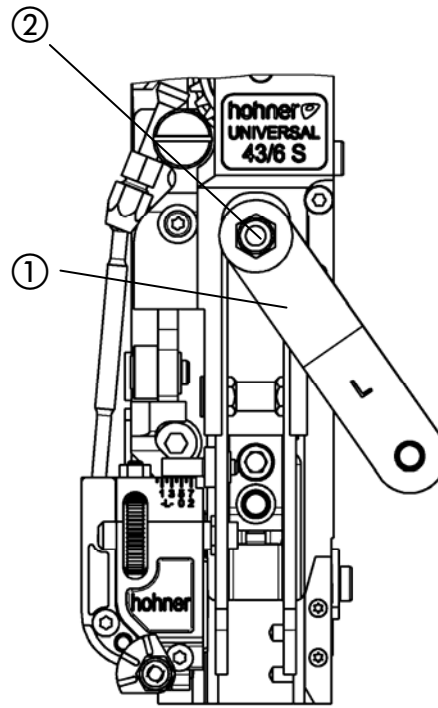

Fig. 20a

Exchangeable parts for standard stitch

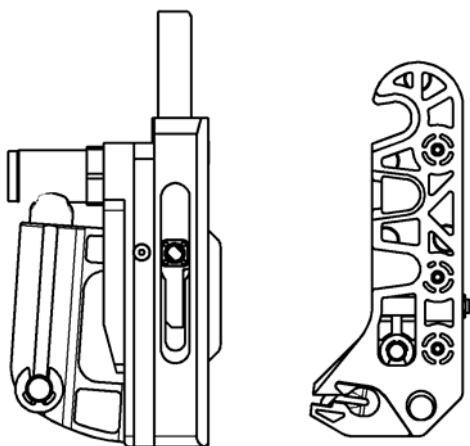

Fig. 21

3.9.1 Exchangeable parts

- Fig. 20, Fig. 20a, Fig. 21 -

To change over from standard stitching to loop stitching, a set of exchangeable parts, art. no. 9964 401 is required, consisting of:

Bender –L6-, cpl.	Art. no. 9964 440
Former –L6-, cpl.	Art. no. 9964 445
Leaf spring -L-	Art. Nr. 3964 427

Or a set of exchangeable parts loop stitch L8, Art.-no. 9964 680, consisting of:

Bender –L8-, cpl.	Art.-no. 9964 678
Former –L8-, cpl.	Art. no. 9964 675
Leaf spring -L-	Art. no. 3964 427

3.9.2 Procedure

- Remove stitching head.
- Install additional leaf spring -L- ①. When installing the leaf spring -L- ①, please tighten the self-locking hexagon head screw ② only so strong, that you can still turn the leaf springs.
- Remove former (cf. 4.2.1 Replacing the former).
- Remove bender (cf. 4.2.3 Replacing the bender).
- Remount bender and former for loop stitching in the inverse order.
- Install and set stitching head.

3.9.3 Adapting the stitch and leg length settings

As the loop stitch requires a longer wire piece, a new setting is required for the stitch and leg length (cf. 3.6 Setting the stitch length).

Operation

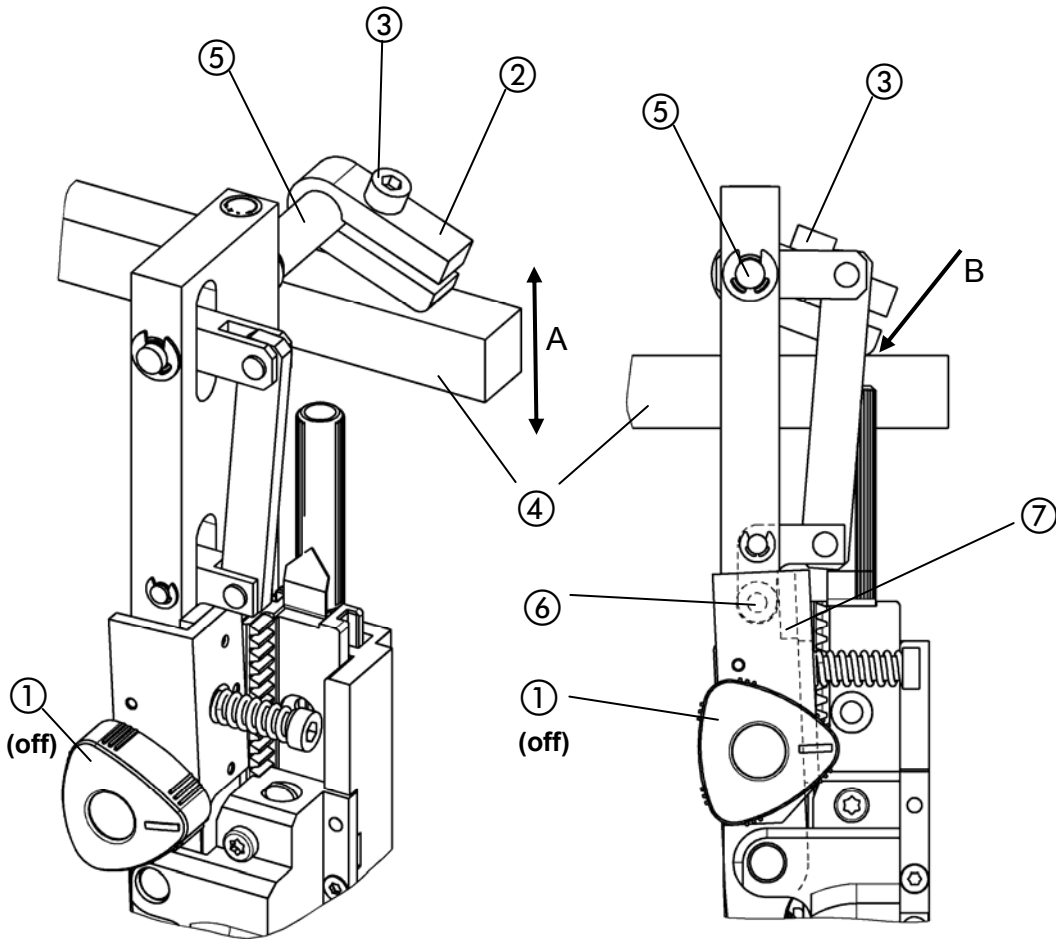

Fig. 22

3.10 Basic setting of Stop-Stitch (ST 100)

- Fig. 22 -

The Stop-Stitch is set with the stitching head installed and with the machine cover open.

- Deactivate the wire transport at the triangular handle ① (marking line points to the right, see Fig. 22).
- Loosen clamping of the switching segment ② at the screw ③.
- Move lifting bar ④ (switch is actuated in case of a waste sheet) upwards (**arrow A**).
- Turn axle ⑤ of the switching segment to the left (anticlockwise) until the bottom rocker ⑥ with the bearing touches the transport lever ⑦.
- Have the switching segment ② lie on the lifting bar ④ (**arrow B**) and tighten screw ③.
- Press lifting bar ④ downwards (**arrow A**).
- Activate wire transport at the triangular handle ① (marking line points upwards or downwards).

4 Servicing

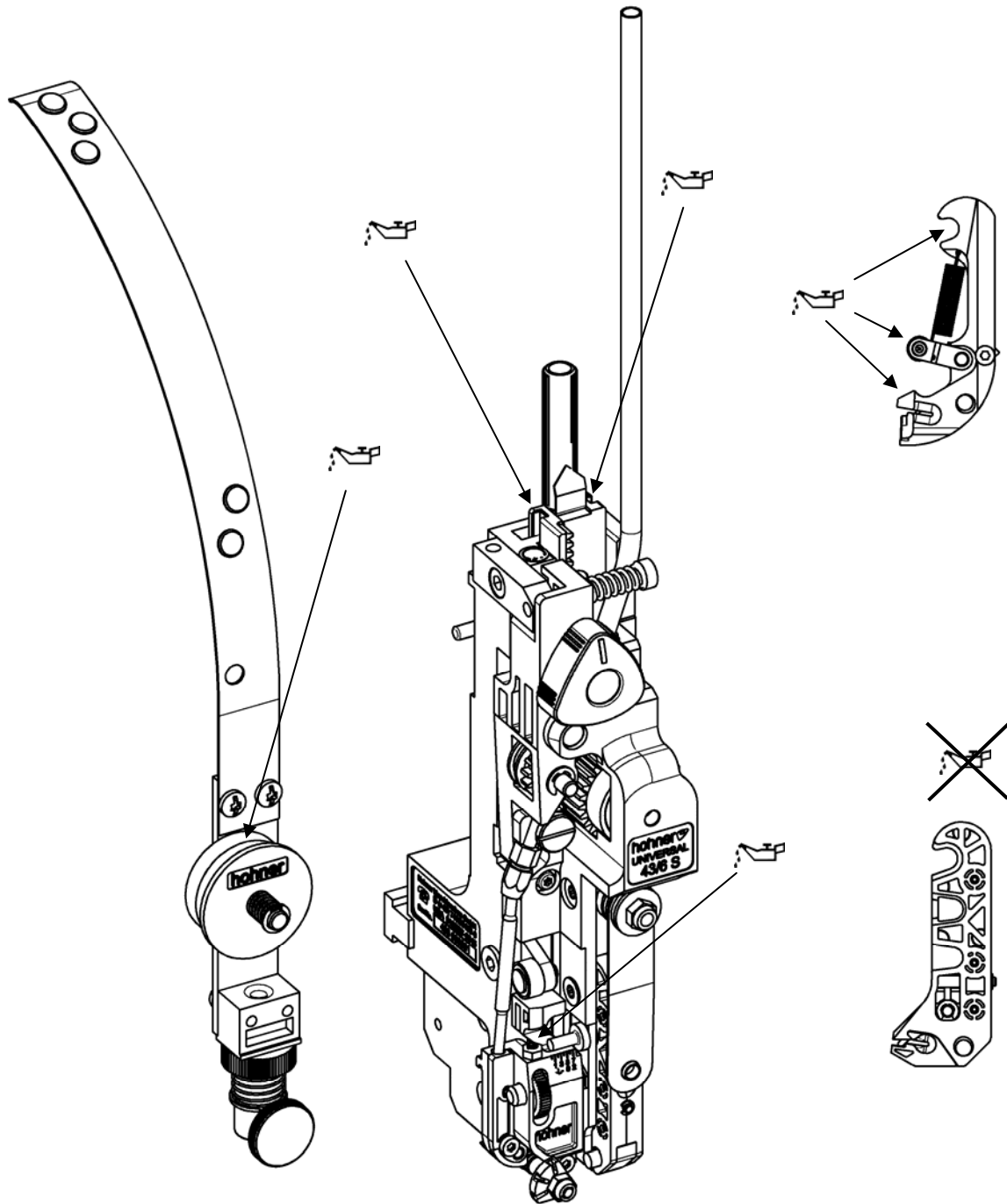

Fig. 23

Servicing

4.2 Installation and replacement of parts

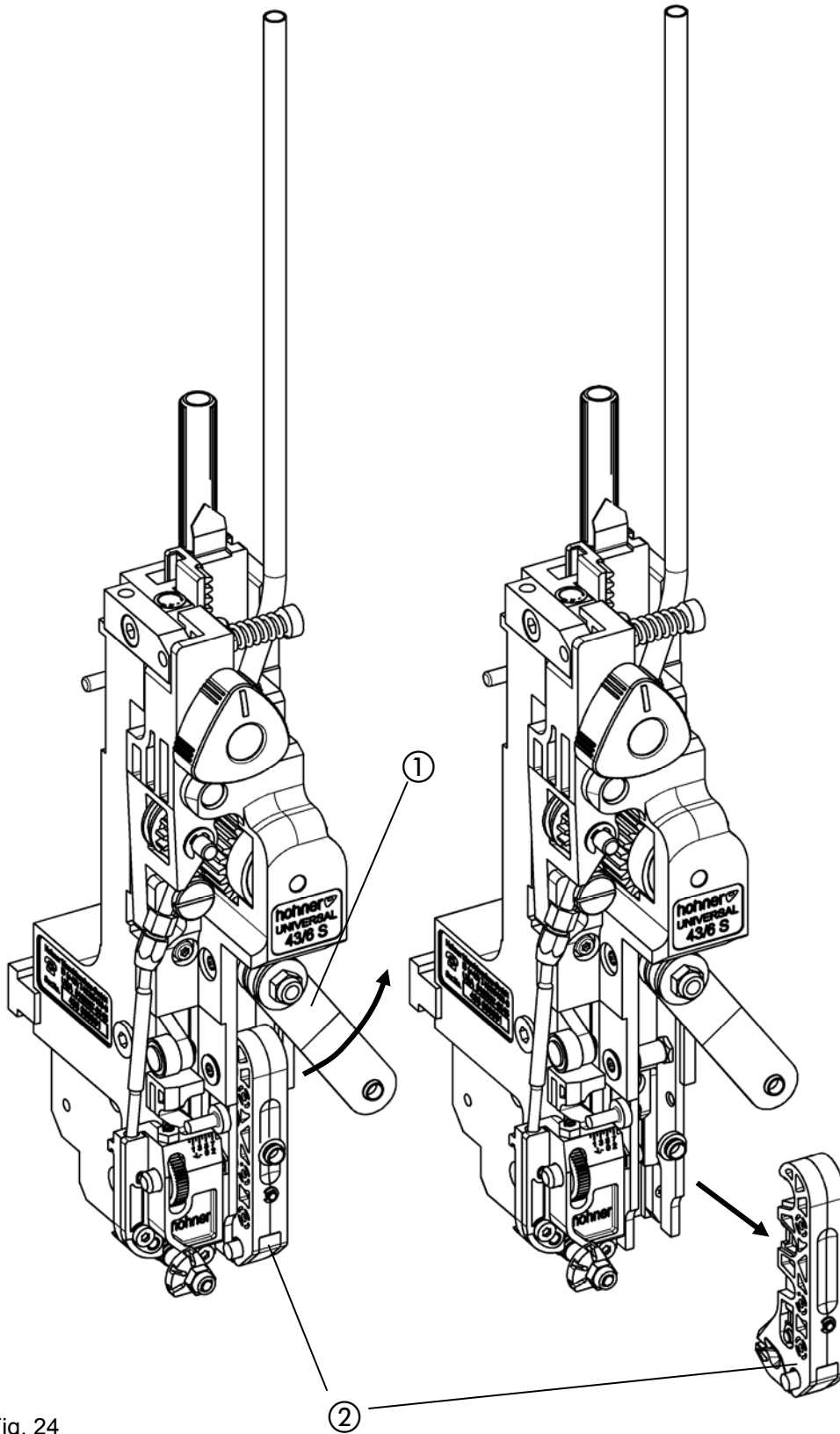

Fig. 24

Fig. 25

4.2.1 Replacing the former

- Fig. 24, Fig. 25 -

- Turn leaf spring ① to the side and remove former ② forwards.

Installation is performed in the reverse.

- Adjust former according to Chap. 3.7.

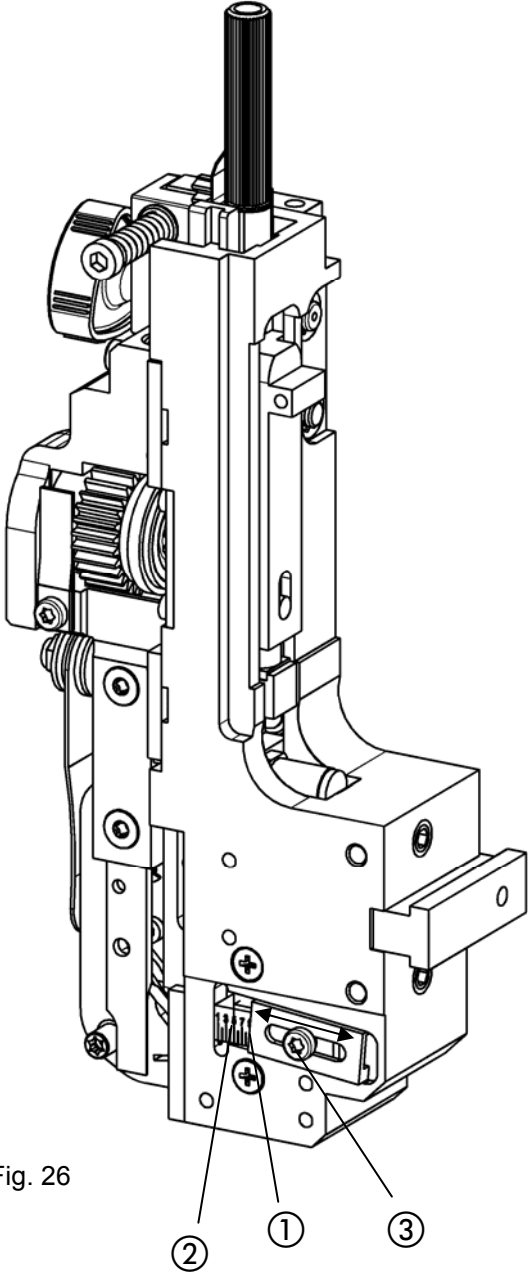

Fig. 26

4.2.2 Removing the bender stop

- Fig. 26 -

The bender stop dictates the lower position of the bender. This stop ensures that the bender does not strike against the product during stitching of thin products and can damage them. The basic setting of the bender stop is performed at the factory.



Before removing the bender stop read off and record the position of the left edge of the slide ① on the scale ②, so that you can subsequently reset the bender stop to the same position.

- Unscrew the screw ③ and remove bender stop ② with slide ①.

Installation is performed in the inverse order.

- First, screw in the screw lightly.
- Reset the slide by moving it to the read off scale value (arrow).
- Tighten the screw.

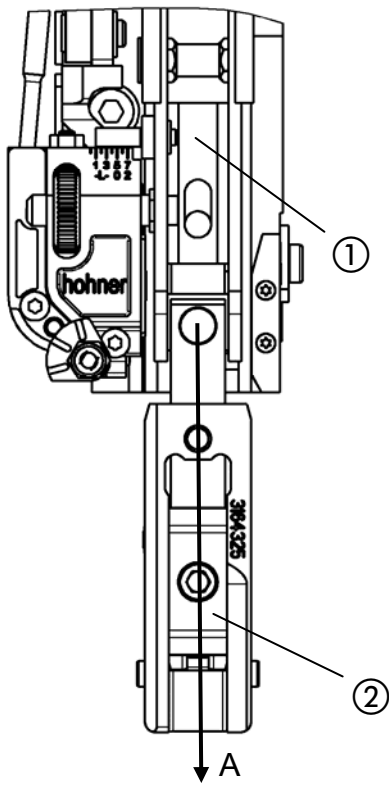

Fig. 27

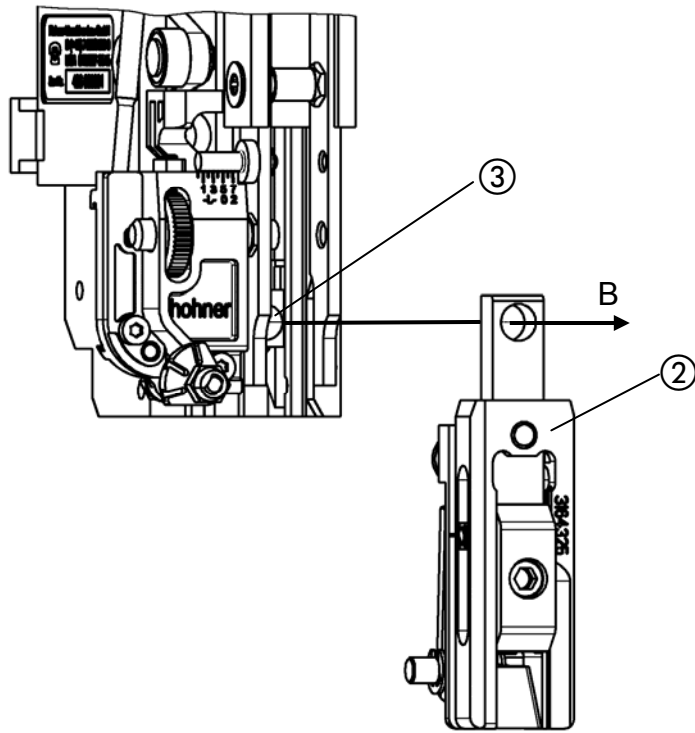

Fig. 28

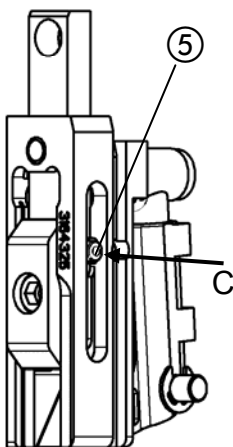

Fig. 29

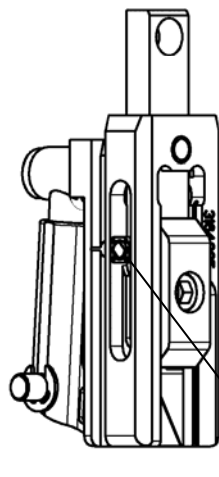

Fig. 30

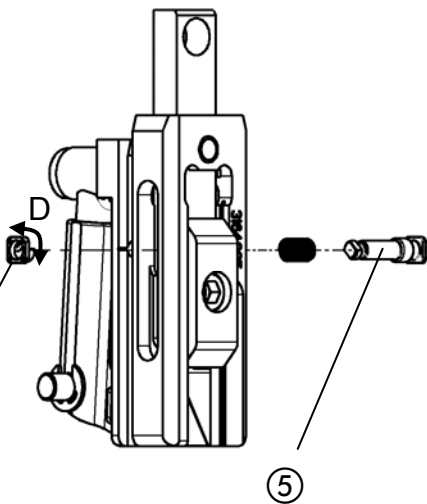

Fig. 31

4.2.3 Replacing the bender

- Fig. 27, Fig. 28 -

To replace the bender, the unit main slide ① - bender ② must be pulled far enough down out of the stitching head to allow the bender to be lifted off the retaining bolt ③ of the main slide.

- Remove bender stop (cf. 4.2.2 Removing the bender stop).
- Remove former (cf. 4.2.1 Replacing the former).
- Push main slide ① with bender ② downwards in the stitching head (arrow A).
- Remove bender from retaining bolt ③ (arrow B).

Installation is performed in the inverse order.

4.2.3.1 Bender lock

Reliable wire forming is ensured by the bender lock fitted in the bender. This prevents the bender from being pushed together in the wire forming phase.

4.2.3.2 Removing the bender lock

- Fig. 29, Fig. 30, Fig. 31 -

- Press actuating pin ⑤ into the bender (arrow C) until the pin retainer ④ protrudes far enough from the bender to enable it to be turned.
- Turn pin retainer by 90° (arrow D) and remove.
- Remove actuating pin with spring.



Installation is performed in the inverse order.

- After fitting **always** check that the pin retainer and limiter pin operate smoothly.

Servicing

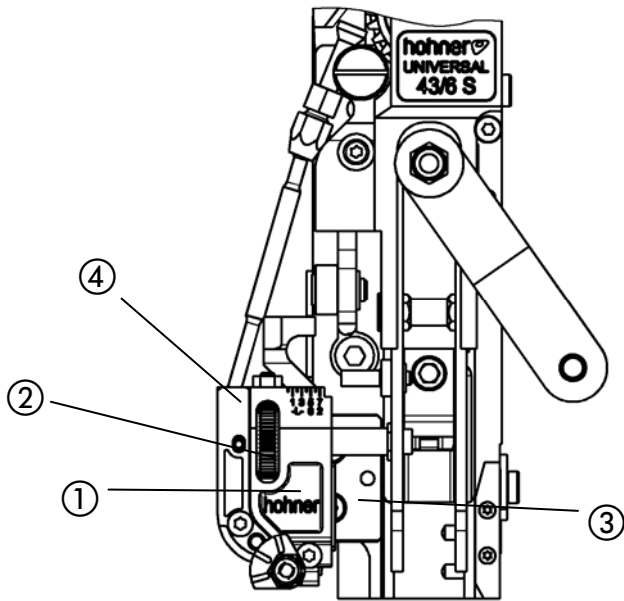

Fig. 32

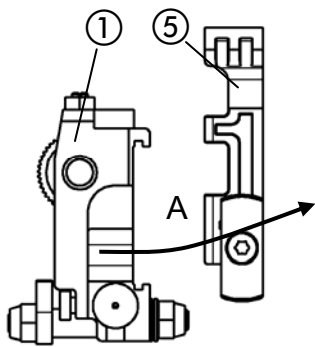

Fig. 33

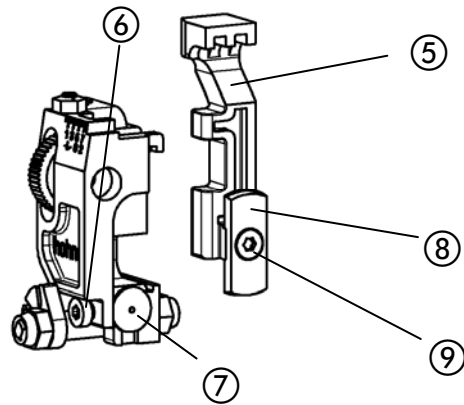

Fig. 34

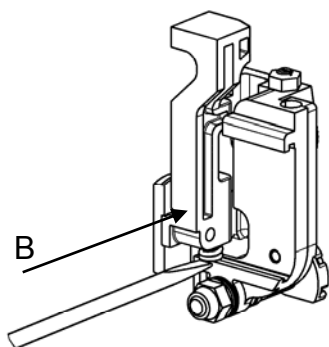

Fig. 35

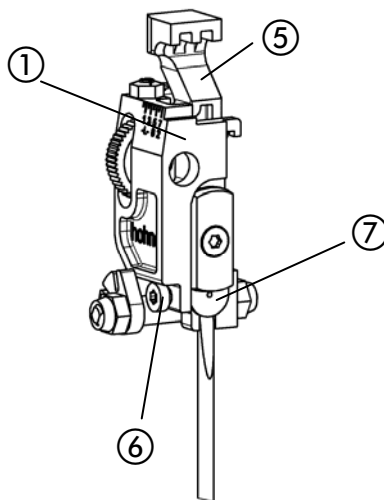

Fig. 36

4.2.4 Replacing the knife

- Fig. 32 -

- To replace the knife, move the knife box ① completely away from the guide ③ by turning the knurling wheel ② and remove from the stitching head.

- Fig. 33 -

- Push the knife slider ⑤ out of the knife box ① (arrow A)
Make sure that the pressure spring doesn't strip.



- Change the knife (see following chapter)

- Fig. 35 -

- Replace knife slider ⑤ in the knife box ① (arrow B), compressing the pressure spring of the knife slider with a screwdriver, and pushing it into the knife box. Make sure that the pressure spring is not bent.



- Fig. 32 -

- Place knife box ① on the guide ③.
- Attach flexible wire feed to drill hole ④ in knife box.
- Return knife box to the desired position by turning the knurling wheel.



4.2.4.1 Rotating/Changing the flat knife

- Fig. 34 -

The flat knife has 2 cutting edges. If the first cutting edge is blunt, the knife can be rotated.

- Unscrew fastening screw ⑨.
- Rotate or replace flat knife ⑧ and tighten fastening screw ⑨.



4.2.4.2 Replacing the circular knife

- Fig. 34 -

- Loosen the clamping screw ⑥ and remove the circular knife ⑦.
- Press new circular knife completely into the seat in the knife box.
- Adjust circular knife (cf. Adjusting the circular knife).

4.2.4.3 Adjusting the circular knife

- Fig. 36 -

The circular knife is adjusted so as to ensure clean cutting of the wire.

When the knives are mounted, set the clearance between the flat and circular knives by carefully "levering" with a screwdriver.

- Loosen clamping screw ⑥ and position circular knife ⑦ exactly against the flat knife by "levering" with a screwdriver.
- Tighten clamping screw ⑥.



If the distance between the knives is set too close the knife slider 5 may block and cause a wire jam.

Servicing

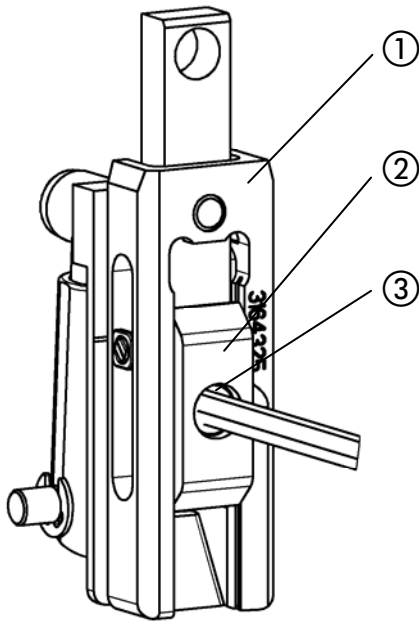

Fig. 37

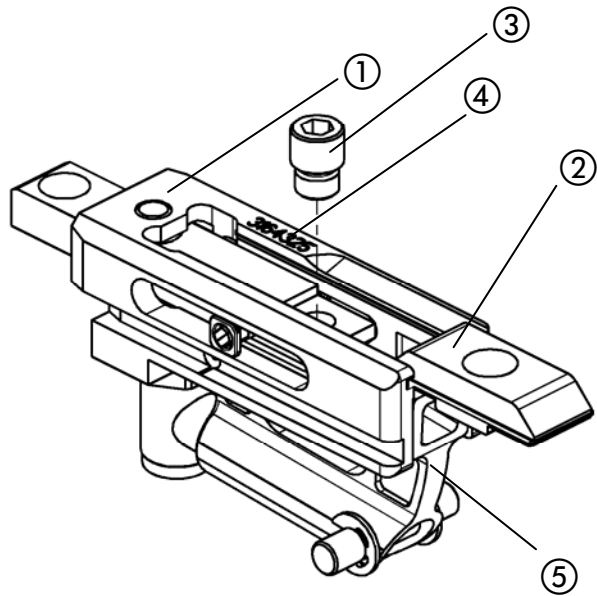

Fig. 38

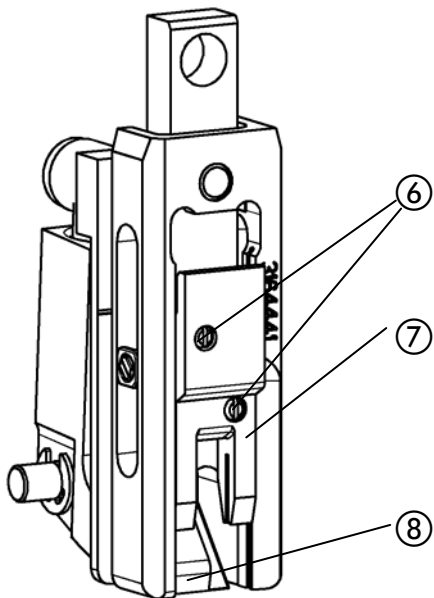

Fig. 39

4.2.5 Replacing the driver (normal stitch)

- Fig. 37, Fig. 38 -



The driver ② can be used twice (only with normal stitching). If one side is damaged or deflected, the driver can be turned round.

Drivers and benders are numbered ④. Care must be taken that drivers are always used with matching benders (see table below), as their wire guiding grooves are different.

- Unscrew fastening screw ③ and push the driver ② down out of the bender.
- Rotate driver.

or

- Change driver.
- Press shoe tongue ⑤ back and push driver into the bender from beneath.
- Secure driver with fastening screw.

Round wire no. 24 - 26 Driver : 31 64 335	with bender: 31 64 325
Round wire no. 26 - 28 Driver : 31 64 337	with bender: 31 64 327

4.2.6 Replacing the driver (loop stitch)

- Fig. 39 -

- Unscrew setscrew ⑥ and push the driver ⑦ down out of the bender.
- Change driver.
- Press shoe tongue ⑧ back and push driver into bender from beneath.
- Secure driver with setscrews.

Standard loop stitch - L6 -:	
Round wire no. 24 - 26 Driver -L-: 31 64 412	with bender -L-: 31 64 441

Loop stitch - L8 -:	
Round wire no. 24 - 26 Driver -L-: 31 64 676	with bender -L-: 31 64 679

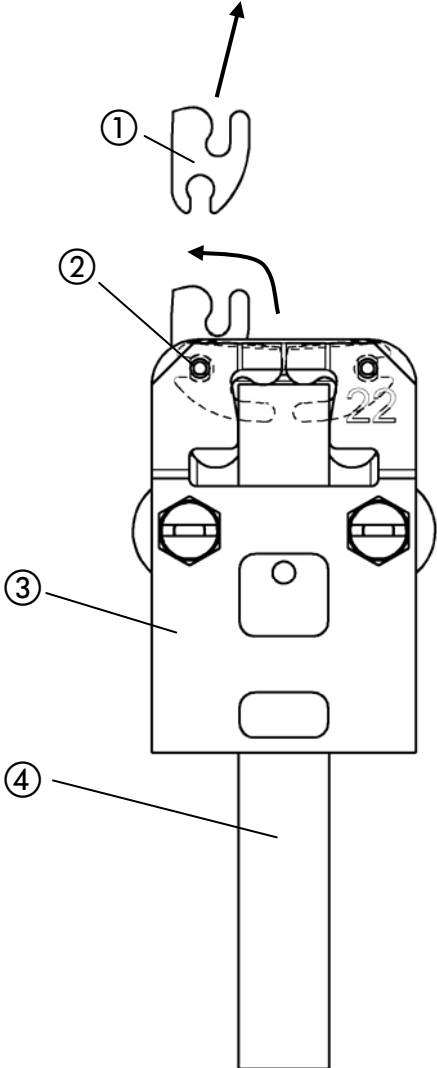

Fig. 40

4.2.7 Replacing the clincher





- Fig. 40 -





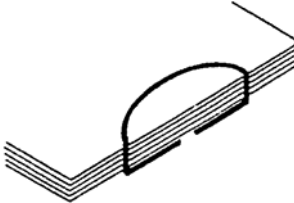
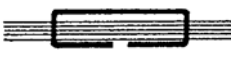



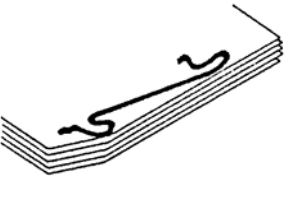

Remove clincher pusher ④ downwards. Turn clincher ① upwards in the clincher box ③ and remove from retention pin ②. Push new clincher onto retention pin and turn to the center of the clincher box. Replace clincher pusher.

5 Faults

5.1 Causes and elimination of faults

Below you will find some examples of faults, with information on the potential cause. If various causes come into consideration, sometimes several suggestions may be made for the remedy: You should not follow all of these before testing the result, but proceed step by step, with intermediate testing. Worn parts should always be replaced.

Stitch	Fault	Potential cause and elimination of the fault
	Back of stitch is bent in a banana shape:	<ul style="list-style-type: none"> - Weak or soft wire. - Wire not aligned, cf. 3.5. - Circular or flat knife worn, cf. 4.2.4. - Shoe tongue pressure too weak: remove obstructing wire pieces or replace pressure spring in shoe tongue. - Wire groove in driver soiled, worn or damaged: remove driver, cf. 4.2.5. Clean driver groove or replace driver.
	Back of stitch not securely positioned:	<ul style="list-style-type: none"> - Stitching not pressed sufficiently: set stitching unit to stitch thickness.
	Stitch legs are not sufficiently clinched:	<ul style="list-style-type: none"> - Stitching not pressed sufficiently: set stitching unit to stitch thickness. - Clincher is not coming up far enough: adjust clincher lift pressure on stitching unit. - Time from clincher activation to lift movement is incorrect: stitching unit must be reset by the manufacturer.
	Back of stitch is not securely positioned and is sagging in a saddle shape:	<ul style="list-style-type: none"> - Stitching not sufficiently pressed: set stitching unit to stitch thickness. - Weak or soft wire. - Shoe tongue pressure too weak: remove obstructing wire pieces or replace pressure spring in shoe tongue.
	Stitch legs are buckled and are not properly clinched:	<ul style="list-style-type: none"> - Weak or soft wire. - Wire not aligned, cf. 3.5. - Align clincher box, cf. 3.1.4. - Different leg lengths, cf. 3.6.3. - Overall wire piece too short, cf. 3.6.2. - Circular or flat knife worn, cf. 4.2.4.
	Wire not penetrating, resulting in loop formation:	<ul style="list-style-type: none"> - Weak or soft wire. - Bender groove blocked by wire pieces. - Circular or flat knife worn, cf. 4.2.4. - Wire groove in driver soiled, worn or damaged: remove driver: clean driver groove or replace driver, cf. 4.2.5. - Shoe tongue pressure too weak: remove obstructing pieces of wire or replace pressure spring in shoe tongue. - Align clincher box, cf. 3.1.4.

	<p>Stitch legs break off:</p>	<ul style="list-style-type: none"> - Bender lock defective, cf. 4.2.3.1. - Wire too brittle: use a different wire quality. - Former blocked by pieces of wire: remove wire pieces, remove former if necessary. - Gripper spring or gripper in former defective. - Wire thickness not suitable for the wire guiding parts (bender and driver). - Adjust former to bender groove.
	<p>Hump at a stitch corner:</p>	<ul style="list-style-type: none"> - Weak or soft wire. - Driver damaged, cf. 4.2.5. - Circular or flat knife worn, cf. 4.2.4. - Wire not aligned, cf. 3.5.
	<p>Stitch legs contract or diverge:</p>	<ul style="list-style-type: none"> - Circular or flat knife worn, cf. 4.2.4. - Wire not aligned, cf. 3.5. - Align clincher box, cf. 3.1.4.
	<p>Leg ends clinched the wrong way round:</p>	<ul style="list-style-type: none"> - Weak or soft wire. - Wire not aligned, cf. 3.5. - Circular or flat knife worn, cf. 4.2.4.
	<p>One or both legs are clinched obliquely:</p>	<ul style="list-style-type: none"> - Clincher damaged, cf. 3.1.3. - Adjustment of clincher box mounting to stitching head mounting, cf. 3.1.4. - Wire not aligned, cf. 3.5.
	<p>Stitch legs are clinched obliquely to the same side:</p>	<ul style="list-style-type: none"> - Adjustment of clincher box mounting to stitching head mounting, cf. 3.1.4. - Wire not aligned, cf. 3.5. - Crimping lock defective, cf. 4.2.3.1. - Bender worn, cf. 4.2.3.
	<p>Lightly bent wire pieces fall out:</p>	<ul style="list-style-type: none"> - Wire not aligned, cf. 3.5. - Cutting slider jammed: circular knife set too tightly to flat knife, cf. 4.2.4.3. - Cutting rocker locked, pressure spring in cutting block defective.
	<p>Wire loop between conveyor wheels and wire guidance tube:</p>	<ul style="list-style-type: none"> - Former incorrectly set, cf. 4.2.1. - Cutting pusher gets caught: <ul style="list-style-type: none"> - compression spring faulty - knife set too strong - bottom wire guides clogged
	<p>Straight wire pieces fall out:</p>	<ul style="list-style-type: none"> - Weak spring pressure on former. - Wire not aligned, cf. 3.5. - Former set incorrectly, cf. 4.2.1.
	<p>Remedy for faults: loop stitching</p>	<p>You will find most faults and their causes in the preceding section.</p>